



RC456

WHEEL RAKE CARRIER

Published 02/11

Part No. 4702C

OPERATOR'S MANUAL



This Operator's Manual is an integral part of the safe operation of this machine and must be maintained with the unit at all times. READ, UNDERSTAND, and FOLLOW the Safety and Operation Instructions contained in this manual before operating the equipment. *C01-Cover*



FC-RK-0002

RHINO

1020 S. Sangamon Ave.
Gibson City, IL 60936
800-446-5158



To the Owner/Operator/Dealer

All implements with moving parts are potentially hazardous. There is no substitute for a cautious, safe-minded operator who recognizes the potential hazards and follows reasonable safety practices. The manufacturer has designed this implement to be used with all its safety equipment properly attached to minimize the chance of accidents.

BEFORE YOU START! Read the safety messages on the implement and shown in your manual. Observe the rules of safety and common sense!



WARNING

TO AVOID SERIOUS INJURY OR DEATH:

1. READ AND UNDERSTAND OPERATOR'S MANUAL.
2. TRACTOR MUST BE EQUIPPED WITH ROLL-OVER PROTECTION (ROPS) AND SWAY CHAINS.
3. ALWAYS WEAR SAFETY GLASSES, SAFETY SHOES AND SEAT BELT FASTENED TIGHTLY.
4. STOP TRACTOR, LOCK BRAKES, AND BLOCK UP OR SUPPORT IMPLEMENT SECURELY BEFORE WORKING UNDER RAISED COMPONENTS.
5. ALLOW NO RIDERS AT ANY TIME ON TRACTOR OR IMPLEMENT. FALLING OFF CAN KILL.
6. KEEP BYSTANDERS CLEAR OF MOVING PARTS AND WORKING AREA. KEEP CHILDREN AWAY!
7. DO NOT LIFT, LOWER, OR OPERATE UNLESS EVERYONE IS CLEAR OF IMPLEMENT.
8. USE INCREASED CAUTION ON SLOPES & NEAR BANKS AND DITCHES TO PREVENT OVERTURN.
9. LOCK LIFT LEVER UP FOR TRANSPORT. HAVE SMV SIGN VISIBLE. FOLLOW LOCAL LAWS.
10. USE PARKING STAND OR BLOCK UP WHEN UNHITCHING FROM TRACTOR.

999200

WARRANTY INFORMATION:

Read and understand the complete Warranty Statement found in this Manual. Fill out the Warranty Registration Form in full and return it to within 30 Days. Make certain the Serial Number of the Machine is recorded on the Warranty Card and on the Warranty Form that you retain

TABLE OF CONTENTS

| | |
|---|------------|
| SAFETY SECTION | 1-1 |
| General Safety Instructions and Practices | 1-2 |
| Operator Safety Instructions and Practices | 1-3 |
| Equipment Operation Safety Instructions and Practices | 1-5 |
| Connecting or Disconnecting Implement Safety Instructions and Practices | 1-8 |
| Transporting Safety Instructions and Practices | 1-9 |
| Maintenance and Service Safety Instructions and Practices | 1-11 |
| Storage and Parking Safety Instructions and Practices | 1-13 |
| Concluding Safety Instructions and Practices | 1-13 |
| Decal Location | 1-15 |
| Decal Description | 1-16 |
| Federal Laws and Regulations | 1-20 |
| INTRODUCTION SECTION | 2-1 |
| ASSEMBLY SECTION..... | 3-1 |
| GENERAL INSTRUCTIONS..... | 3-2 |
| ASSEMBLY INSTRUCTIONS..... | 3-3 |
| OPERATION SECTION | 4-1 |
| OPERATOR REQUIREMENTS | 4-3 |
| TRACTOR REQUIREMENTS..... | 4-4 |
| ROPS and Seat Belt | 4-4 |
| Tractor Safety Devices..... | 4-4 |
| Tractor Horsepower | 4-4 |
| GETTING ON AND OFF THE TRACTOR | 4-5 |
| Boarding the Tractor | 4-5 |
| Dismounting the Tractor..... | 4-5 |
| STARTING THE TRACTOR | 4-6 |
| CONNECTING THE IMPLEMENT TO THE TRACTOR | 4-7 |
| SETTING THE IMPLEMENT | 4-7 |
| Hydraulics | 4-7 |
| Setting the Rake | 4-8 |
| Wing Adjustment..... | 4-8 |
| Adjusting Ground Pressure | 4-9 |
| PRE-OPERATION INSPECTION AND SERVICE | 4-10 |
| Tractor Pre-Operation Inspection/Service..... | 4-11 |
| Rake Pre-Operation Inspection/Service..... | 4-11 |
| DRIVING THE TRACTOR AND IMPLEMENT | 4-16 |
| Starting the Tractor | 4-17 |
| Brake and Differential Lock Setting..... | 4-17 |
| Driving the Tractor and Implement..... | 4-18 |
| OPERATING THE TRACTOR AND IMPLEMENT | 4-18 |
| Foreign Debris Hazards | 4-19 |
| Bystanders/Passersby Precautions | 4-19 |
| Engaging the Power Take Off (PTO)..... | 4-19 |
| PTO RPM and Ground Speed | 4-19 |
| Shutting Down the Implement..... | 4-20 |

| | |
|---|------|
| DISCONNECTING THE IMPLEMENT FROM THE TRACTOR..... | 4-21 |
| RAKE STORAGE..... | 4-22 |
| TRANSPORTING THE TRACTOR AND IMPLEMENT | 4-22 |
| Transporting..... | 4-24 |
| Transporting on Public Roadways | 4-25 |
| Hauling the Tractor and Implement..... | 4-26 |
| TROUBLESHOOTING GUIDE | 4-28 |

MAINTENANCE SECTION **5-1**

| | |
|--------------------------|-----|
| STORAGE | 5-3 |
| LUBRICATION | 5-4 |
| BOLT TORQUE VALUES | 5-5 |

SAFETY SECTION

Safety Section 1-1

SAFETY

General Safety Instructions and Practices

A careful operator is the best operator. Safety is of primary importance to the manufacturer and should be to the owner/operator. Most accidents can be avoided by being aware of your equipment, your surroundings, and observing certain precautions. The first section of this manual includes a list of Safety Messages that, if followed, will help protect the operator and bystanders from injury or death. Read and understand these Safety Messages before assembling, operating or servicing this Implement. This equipment should only be operated by those persons who have read the manual, who are responsible and trained, and who know how to do so responsibly.



The Safety Alert Symbol combined with a Signal Word, as seen below, is used throughout this manual and on decals which are attached to the equipment. The Safety Alert Symbol means: "ATTENTION! BECOME ALERT! YOUR SAFETY IS INVOLVED!" The Symbol and Signal Word are intended to warn the owner/operator of impending hazards and the degree of possible injury faced when operating this equipment.

Practice all usual and customary safe working precautions and above all---remember safety is up to YOU. Only YOU can prevent serious injury or death from unsafe practices.



Indicates an imminently hazardous situation that, if not avoided, WILL result in DEATH OR VERY SERIOUS INJURY.



Indicates an imminently hazardous situation that, if not avoided, COULD result in DEATH OR SERIOUS INJURY.



Indicates an imminently hazardous situation that, if not avoided, MAY result in MINOR INJURY.



Identifies special instructions or procedures that, if not strictly observed, could result in damage to, or destruction of the machine, attachments or the environment.

NOTE: *Identifies points of particular interest for more efficient and convenient operation or repair.*(SG-1)

READ, UNDERSTAND, and FOLLOW the following Safety Messages. Serious injury or death may occur unless care is taken to follow the warnings and instructions stated in the Safety Messages. Always use good common sense to avoid hazards. (SG-2)



Si no lee ingles, pida ayuda a alguien que si lo lea para que le traduzca las medidas de seguridad. (SG-3)

¡ LEA EL INSTRUCTIVO!



SAFETY



Engine Exhaust, some of its constituents, and certain vehicle components contain or emit chemicals known to the state of California to cause cancer and birth defects or other reproductive harm. (SG-30)



Battery posts, terminals and related accessories contain lead and lead compounds, chemicals known to the state of California to cause cancer, birth defects or other reproductive harm. (SG-31)

Operator Safety Instructions and Practices



Never operate the Tractor or Implement until you have read and completely understand this Manual, the Tractor Operator's Manual, and each of the Safety Messages found in the Manual or on the Tractor and Implement. Learn how to stop the tractor engine suddenly in an emergency. Never allow inexperienced or untrained personnel to operate the Tractor or Implement without supervision. Make sure the operator has fully read and understood the manuals prior to operation. (SG-4)

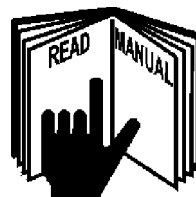

The operator and all support personnel should wear hard hats, safety shoes, safety glasses, and proper hearing protection at all times for protection from injury including injury from items that may be thrown by the equipment. (SG-16)

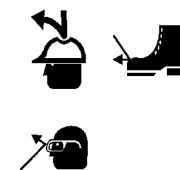

PROLONGED EXPOSURE TO LOUD NOISE MAY CAUSE PERMANENT HEARING LOSS! Tractors with or without an Implement attached can often be noisy enough to cause permanent hearing loss. We recommend that you always wear hearing protection if the noise in the Operator's position exceeds 80db. Noise over 85db over an extended period of time will cause severe hearing loss. Noise over 90db adjacent to the Operator over an extended period of time will cause permanent or total hearing loss. **NOTE:** *Hearing loss from loud noise [from tractors, chain saws, radios, and other such sources close to the ear] is cumulative over a lifetime without hope of natural recovery.* (SG-17)



Always read carefully and comply fully with the manufacturer's instructions when handling oil, solvents, cleansers, and any other chemical agent. (SG-22)

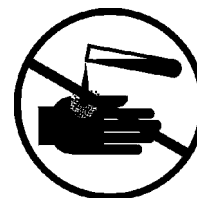

SAFETY

SAFETY



KEEP AWAY FROM ROTATING ELEMENTS to prevent entanglement and possible serious injury or death. (SG-24)



Never allow children to play on or around Tractor or Implement. Children can slip or fall off the Equipment and be injured or killed. Inadvertent contact with controls can cause the Implement to shift or fall crushing themselves or others. (SG-25)



DO NOT use drugs or alcohol immediately before or while operating the Tractor and Implement. Drugs and alcohol will affect an operator's alertness and coordination and therefore affect the operator's ability to operate the equipment safely. Before operating the Tractor or Implement, an operator on prescription or over-the-counter medication must consult a medical professional regarding any side effects of the medication that would hinder their ability to operate the Equipment safely. NEVER knowingly allow anyone to operate this equipment when their alertness or coordination is impaired. Serious injury or death to the operator or others could result if the operator is under the influence of drugs or alcohol. (SG-27)

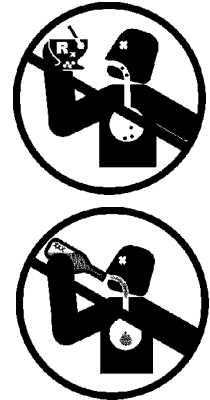

Prolonged operation may cause operator boredom and fatigue affecting safe operation. Take scheduled work breaks to help prevent these potentially impaired operating conditions. Never operate the Implement and Tractor in a fatigued or bored mental state which impairs proper and safe operation. (SG-32)



Use extreme caution when getting onto the Implement to perform repairs, maintenance and when removing accumulated material. Only stand on solid flat surfaces to ensure good footing. Use a ladder or raised stand to access high spots which cannot be reached from ground level. Slipping and falling can cause serious injury or death. (SG-33)



Avoid contact with hot surfaces including hydraulic oil tanks, pumps, motors, valves and hose connections. Relieve hydraulic pressure before performing maintenance or repairs. Use gloves and eye protection when servicing hot components. Contact with a hot surface or fluid can cause serious injury from burns or scalding. (SG-34)



DO NOT operate this Implement on a Tractor that is not properly maintained. Should a mechanical or Tractor control failure occur while operating, immediately shut down the Tractor and perform repairs before resuming operation. Serious injury and possible death could occur from not maintaining this Implement and Tractor in good operating condition. (SG-36)

SAFETY



WARNING

Extreme caution should be used by the Tractor operator when operating near passersby. Stop raking if anyone comes within 25 feet of the Implement to prevent possible passerby injury or death from being struck from a thrown object, entanglement with the rakes, or run over. (SRK-01)

Equipment Operation Safety Instructions and Practices



CAUTION

Do not back up with this implement. Backing could damage the machine or its components. (S3PT-4)



WARNING

Use extreme care when lowering or unfolding the implement's wings. Make sure no bystanders are close by or underneath the wings. Allow ample clearance around the implement when folding or unfolding the wings. Use extreme caution around buildings or overhead power lines. (S3PT-05)



DANGER

There are obvious and hidden potential hazards in the operation of this Implement as in all power-driven or pulled equipment. REMEMBER! This machine is often operated in rough terrain conditions that include tall grass, weeds, gullies, holes, slopes, hidden obstructions and the like. Serious injury or even death may occur unless care is taken to assure the safety of the operator and bystanders in the area. Do not operate this machine with anyone in the immediate area. (S3PT-07)



DANGER

This Implement may be wider than the Tractor. Be careful when operating or transporting this equipment to prevent the Implement from running into or striking sign posts, guard rails, concrete abutments or other solid objects. Such an impact could cause the Implement and Tractor to pivot violently resulting in loss of steering control, serious injury, or even death. Never allow the Implement to contact obstacles. (S3PT-12)



WARNING

Operate this Implement only in conditions where you have clear visibility in daylight or with adequate artificial lighting. Never operate in darkness or foggy conditions where you cannot clearly see at least 100 yards in front and to the sides of the tractor and implement. Make sure that you can clearly see and identify passersby, steep slopes, ditches, drop-offs, overhead obstructions, power lines, debris and foreign objects. If you are unable to clearly see this type of items discontinue operating this equipment. (S3PT-21)



WARNING

Operate this Equipment only with a Tractor equipped with an approved roll-over-protective system (ROPS). Always wear seat belts. Serious injury or even death could result from falling off the tractor--particularly during a turnover when the operator could be pinned under the ROPS. (SG-7)



SAFETY

SAFETY



BEFORE leaving the tractor seat lower the implement, set the parking brake and/or set the tractor transmission in parking gear, disengage the PTO, stop the engine, remove the key, and wait for all moving parts to stop. Place the tractor shift lever into a low range or parking gear to prevent the tractor from rolling. Never dismount a Tractor that is moving or while the engine is running. Operate the Tractor controls from the tractor seat only. (SG-9)

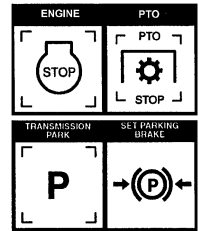

Never allow children or other persons to ride on the Tractor or Implement. Falling off can result in serious injury or death. (SG-10)



Never allow children to operate, ride on, or come close to the Tractor or Implement. Usually, 16-17 year-old children who are mature and responsible can operate the implement with adult supervision, if they have read and understand the Operator's Manuals, been trained in proper operation of the tractor and Implement, and are physically large enough to reach and operate the controls easily. (SG-11)



Do not mount or dismount the Tractor while the tractor is moving. Mount the Tractor only when the Tractor and all moving parts are completely stopped. (SG-12)



Start tractor only when properly seated in the Tractor seat. Starting a tractor in gear can result in injury or death. Read the Tractor operators manual for proper starting instructions. (SG-13)



Do not operate this Equipment with hydraulic oil or fuel leaking. Oil and fuel are explosive and their presence could present a hazard. Do not check for leaks with your hand! High-pressure oil streams from breaks in the line could penetrate the skin and cause tissue damage including gangrene. To check for a hose leak, SHUT the unit ENGINE OFF and remove all hydraulic pressure. Wear oil impenetrable gloves, safety glasses and use Cardboard to check for evidence of oil leaks. If you suspect a leak, REMOVE the HOSE and have it tested at a Dealer. If oil does penetrate the skin, have the injury treated immediately by a physician knowledgeable and skilled in this procedure. (SG-15)



SAFETY



Never run the Tractor engine in a closed building or without adequate ventilation. The exhaust fumes can be hazardous to your health. (SG-23)



Do not exceed the rated PTO speed for the Implement. Excessive PTO speeds can cause Implement driveline or blade failures resulting in serious injury or death. (SG-26)



Operate the Tractor and/or Implement controls only while properly seated in the Tractor seat with the seat belt securely fastened around you. Inadvertent movement of the Tractor or Implement may cause serious injury or death. (SG-29)



In case of mechanical difficulty during operation, place the transmission in the park position, set the parking brake, shut down all power, including the PTO and the engine and remove the key. Wait until all rotating motion has stopped before dismounting. (SG-39)



Do Not operate this equipment in areas where insects such as bees may attack you and/or cause you to lose control of the equipment. If you must enter in such areas, use a tractor with an enclosed Cab and close the windows to prevent insects from entering. If a tractor cab is not available, wear suitable clothing including head, face, and hand protection to shield you from the insects. Attacking insects can cause you to lose control of the tractor, which can result in serious injury or death to you or bystanders. Never dismount a moving tractor. (SG-40)



Objects such as wire, cable, rope, and chain can become entangled in the rotating parts of the raking components causing mechanical damage. Entangled items caught in the rakes can sling outward possibly injuring or entangling the operator or passersby. Any objects that might become entangled in a raking component should be removed from the area before operating the rake. (SRK-02)



DO NOT allow any person under a folded wing unless wing is securely locked up or supported. **DO NOT** approach the Implement unless the Tractor is turned off and all motion has ceased. Never work under the frame work, or any lifted component unless the implement is securely supported or blocked up. A sudden or inadvertent fall by any of these components could cause serious injury or even death. (STI-03)



SAFETY

Connecting or Disconnecting Implement Safety Instructions and Practices



DO NOT use a PTO adapter to attach a non-matching Implement driveline to a Tractor PTO. Use of an adapter can double the operating speed of the Implement resulting in excessive vibration, thrown objects, and blade and implement failure. Adapter use will also change the working length of the driveline exposing unshielded driveline areas. Serious bodily injury and/or equipment failure can result from using a PTO adapter. Consult an authorized dealer for assistance if the Implement driveline does not match the Tractor PTO.

(S3PT-14)



Always shut the Tractor completely down, place the transmission in park, and set the parking brake before you or anyone else attempts to connect or disconnect the Implement and Tractor hitches. (S3PT-15)



When attaching the Implement input driveline to the Tractor PTO, it is important that the connecting yoke spring activated locking collar slides freely and the locking balls are seated securely in the groove on the Tractor PTO shaft. Push and pull the driveline back and forth several times to ensure it is securely attached. A driveline not attached correctly to the Tractor PTO shaft could come loose and result in personal injury and damage to the Implement. (S3PT-17)



Before operating the Implement, check to make sure the Implement input driveline will not bottom out or become disengaged. Bottoming out occurs when the inner shaft penetrates the outer housing until the assembly becomes solid-it can shorten no more. Bottoming out can cause serious damage to the Tractor PTO by pushing the PTO into the Tractor and through the support bearings or downward onto the PTO shaft, breaking it off. A broken driveline can cause personal injury. (S3PT-18)



Never unhitch without using the Tongue Jack. The Tongue is very heavy. Attempting to lift the Tongue without using the Tongue Jack could cause strains or other injury. Allowing the tongue to fall suddenly and unexpectedly could result in crushing injury. Use the Tongue Jack for lifting the Implement only. Overloading the Tongue Jack can cause failure with possible serious bodily injury or even death. (STI-04)



On a fully-assembled unit, do not remove the Wing Retaining Strap until hoses are attached to the tractor and the Wing Cylinders are filled with oil. Lower the Wings slowly and carefully. Keep bystanders away during operations. (STI-05)

SAFETY

Transporting Safety Instructions and Practices



Be particularly careful when transporting the Implement with the Tractor. Turn curves or go up hills only at a low speed and using a gradual steering angle. Rear mounted implements move the center of gravity to the rear and remove weight from the front wheels. Make certain, by adding front ballast, that at least 20% of the tractor's weight is on the front wheels to prevent rearing up, loss of steering control or Tractor tip-over. Slow down on rough or uneven surfaces to prevent loss of steering control which could result in property damage or possible injury. Do not transport unless 3-Point lift lever is fully raised and in the latched transport position. Dropping implement in transport can cause serious damage to the tractor and/or Implement and possibly cause the operator or others to be injured or killed.

(S3PT-02)



Allow sufficient clearance for the Implement to swing outward while turning. Implements carried behind the Tractor will swing outside the tire path when making turns. Contacting a solid object while turning will cause equipment damage and possible injury. (S3PT-20)



Make certain that the "Slow Moving Vehicle" (SMV) sign is installed in such a way as to be clearly visible and legible. When transporting the Equipment use the Tractor flashing warning lights and follow all local traffic regulations. (SG-6)

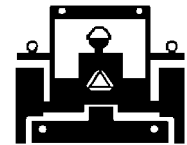

SAFETY

SAFETY

WARNING

Transport only at speeds where you can maintain control of the equipment. Serious accidents and injuries can result from operating this equipment at high speeds. Understand the Tractor and Implement and how it handles before transporting on streets and highways. Make sure the Tractor steering and brakes are in good condition and operate properly.



Before transporting the Tractor and Implement, determine the proper transport speeds for you and the equipment. Make sure you abide by the following rules:

Test the tractor at a slow speed and increase the speed slowly. Apply the Brakes smoothly to determine the stopping characteristics of the Tractor and Implement. As you increase the speed of the Tractor the stopping distance increases. Determine the maximum transport speed not to exceed 20 mph (30 kph) for transporting this equipment.

Test the equipment at a slow speed in turns. Increase the speed through the turn only after you determine that the equipment can be operated at a higher speed. Use extreme care and reduce your speed when turning sharply to prevent the tractor and implement from turning over. Determine the maximum turning speed for you and this equipment before operating on roads or uneven ground.

Only transport the Tractor and Implement at the speeds which allow you to properly control the equipment.

Be aware of the operating conditions. Do not operate the Tractor with weak or faulty brakes or worn tires. When operating down a hill or on wet or rain slick roads, the braking distance increases: use extreme care and reduce your speed. When operating in traffic always use the Tractor's flashing warning lights and reduce your speed. Be aware of traffic around you and watch out for the other guy. (SG-19)



DANGER

Be particularly careful when transporting the Implement using the tractor. Turn curves or go up or down hills only at a low speed and at a gradual steering angle. Make certain that at least 20% of the tractor's weight is on the front wheels to maintain safe steering. Slow down on rough or uneven surfaces. (STI-01)

DANGER

When the Wings are folded for transport, the center of gravity is raised and the possibility of overturn is increased. Drive slowly and use extreme caution when turning on hillsides. Overturning the Implement could cause the Implement to overturn the Tractor and vice versa resulting in serious injury or even death. Never fold wings on a hillside...the Implement or unit may overturn. (STI-02)

WARNING

Only tow the Implement behind a properly sized and equipped Tractor which exceeds the weight of the Implement by at least 20%. DO NOT tow the Implement behind a truck or other type of vehicle. Never tow the Implement and another Implement connected in tandem. Never tow the Implement at speeds over 20 MPH. (STI-06)



SAFETY



Secure the Implement for transport before traveling on public roads. For pull-type Implements, secure the center axle using cylinder stops or transport pin and properly attach a safety chain between the Implement and Tractor. Secure wings in upright position on folding Implements using wing transport locks. (STI-7)



Always keep a careful lookout and use extreme care when working around overhead obstructions and electrical power lines. The Implement wing can be over 10 feet high. Never allow the Implement wing to come within 10 feet of any power line. (STI-8)



Your driving vision may be reduced or impaired by the tractor, cab, or implement. Before driving on public roadways identify any limited vision areas, and make adjustments to your operating position, mirrors, and the implement transport position so that you can clearly see the area where you will be traveling, and any traffic that may approach you. Failure to maintain adequate vision of the public roadway and traffic can result in serious injury or even death. (STI-10)

SAFETY

Maintenance and Service Safety Instructions and Practices



Make sure the PTO shield, integral driveline shields, and input shields are installed when using PTO-driven equipment. Always replace any shield if it is damaged or missing. (S3PT-8)



Relieve hydraulic pressure prior to doing any maintenance or repair work on the Implement. Place the Implement on the ground or securely blocked up, disengage the PTO, and turn off the tractor engine. Push and pull the Remote Cylinder lever in and out several times prior to starting any maintenance or repair work. (S3PT-09)



Always disconnect the main PTO Driveline from the Tractor before performing service on the Implement. Never work on the Implement with the tractor PTO driveline connected and running. Rotating Parts, Blades or Drivelines could turn without warning and cause immediate entanglement, injury or death. (S3PT-11)



Keep fingers clear of adjusting holes. A sudden movement could cause injury or even amputate fingers. KEEP CHILDREN AWAY WHEN MAKING ADJUSTMENTS. (SBL-3)



Always maintain the safety signs in good readable condition. If the safety signs are missing, damaged, or unreadable, obtain and install replacement safety signs immediately. (SG-5)

SAFETY



Do not modify or alter this Implement. Do not permit anyone to modify or alter this Implement, any of its components or any Implement function. (SG-8)



Never work under the Implement, the framework, or any lifted component unless the Implement is securely supported or blocked up to prevent sudden or inadvertent falling which could cause serious injury or even death. (SG-14)



Never attempt to lubricate, adjust, or remove material from the Implement while it is in motion or while tractor engine is running. (SG-20)



Periodically inspect all moving parts for wear and replace when necessary with authorized service parts. Look for loose fasteners, worn or broken parts, and leaky or loose fittings. Make sure all pins have cotter pins and washers. Serious injury may occur from not maintaining this machine in good working order. (SG-21)

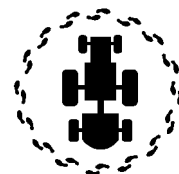

Perform service, repairs and lubrication according to the maintenance section. Ensure the unit is properly lubricated as specified in the lubrication schedule and all bolts and nuts are properly torqued. Failure to properly service, repair and maintain this Implement in good operating condition could cause component failure and possible serious injury or even death. (SG-35)



Use caution and wear protective gloves when handling sharp objects such as blades, knives, and other cutting edges. Be alert to worn component surfaces which have sharp edges. Sharp surfaces can inflict severe laceration injuries if proper hand protection is not worn. (SG-37)

PARTS INFORMATION

Rhino products are designed utilizing specifically matched system components to ensure optimum equipment performance. These parts are made and tested to Rhino specifications. Non-genuine "will fit" parts do not consistently meet these specifications. The use of "will fit" parts may reduce equipment performance, void warranties, and present a safety hazard. Use genuine Rhino parts for economy and safety. (SPRM-2)

SEE YOUR RHINO DEALER

SAFETY

Storage and Parking Safety Instructions and Practices



A rear Implement can fall if not properly supported. Always use the stand on the front hitch (if equipped) or block up securely to prevent falling and possible crushing injury and/or other injury from holding or lifting heavy components. Use the stand to stabilize the implement during storage. (S3PT-3)



To prevent tipping of Implement when stored in folded position, use carrying wheels or adequate stands on center frame. (S3PT-6)

Concluding Safety Instructions and Practices

In addition to the design and configuration of this Implement, including Safety Signs and Safety Equipment, hazard control and accident prevention are dependent upon the awareness, concern, prudence, and proper training of personnel involved in the operation, transport, maintenance, and storage of the machine. Refer also to Safety Messages and operation instruction in each of the appropriate sections of the Tractor and Equipment Manuals. Pay close attention to the Safety Signs affixed to the Tractor and Equipment. (SG-18)

SAFETY

SAFETY

SAFETY

| ITEM | PART NO. | QTY | TYPE | DESCRIPTION |
|------|----------|-----|-------------|--|
| 1. | 999200 | 1 | WARNING | To Avoid Serious Injury or Death |
| 2. | 00760657 | 1 | IMPORTANT | Use Genuine Rhino Parts |
| 3. | 00763977 | 1 | INFORMATION | Notice to Owner |
| 4. | 00725746 | 1 | PELIGRO | Spanish Translation |
| 5. | 3048304 | 1 | WARNING | Multi-Hazard |
| 6. | D302 | 2 | LOGO | Rhino Logo |
| 7. | 3048302 | 2 | LOGO | Model Name - RC456 |
| 8. | 02962765 | 2 | WARNING | Multi-Hazard |
| 9. | 3048303 | 2 | WARNING | Stay Clear |
| 10. | 5W119 | 1 | WARNING | Speed Restriction |
| 11. | 999001 | 1 | WARNING | Multi-Hazard |
| 12. | 2738332 | 2 | REFLCTR | Red Oblong Reflector |
| 13. | 02962764 | 4 | WARNING | Pinch Points |
| 14. | 02965262 | 1 | WARNING | Oil Leak |
| 15. | 3668308 | 2 | WARNING | Install transport lock when in transport |
| 16. | 03200347 | 1 | REFLCTR | SMV Emblem |
| 17. | 3668615 | 1 | SER PLT | Serial Plate |

* Furnished by tractor manufacturer.

SAFETY

Decal Location

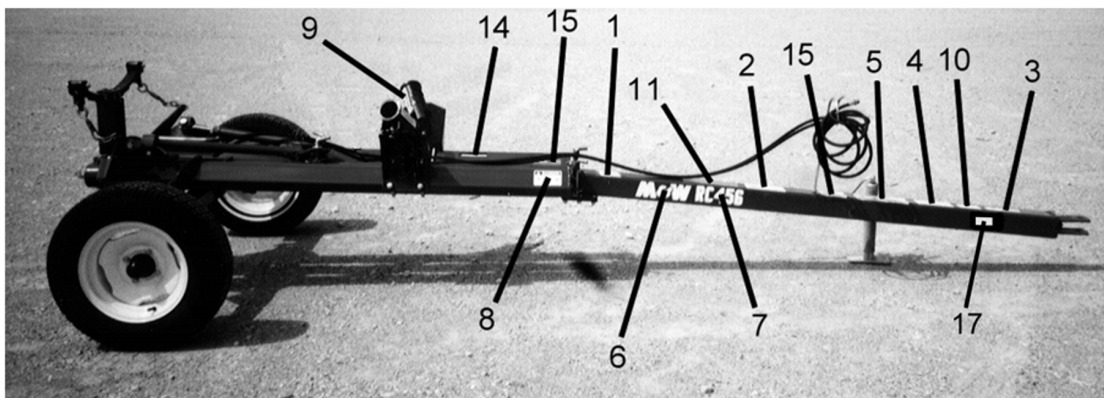
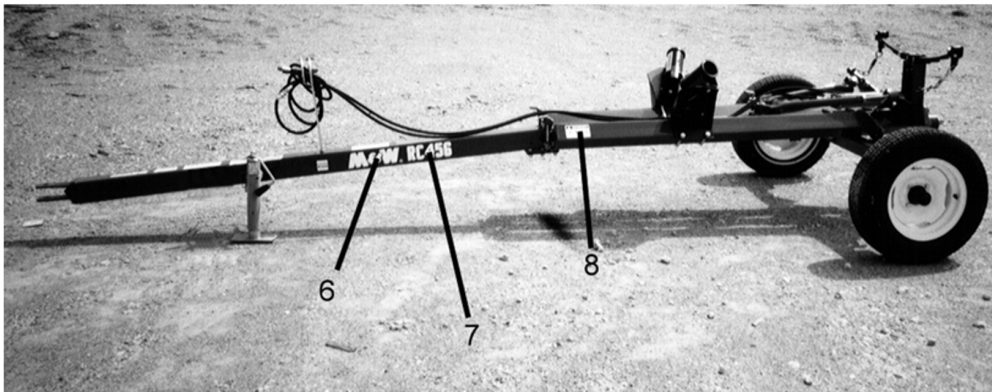
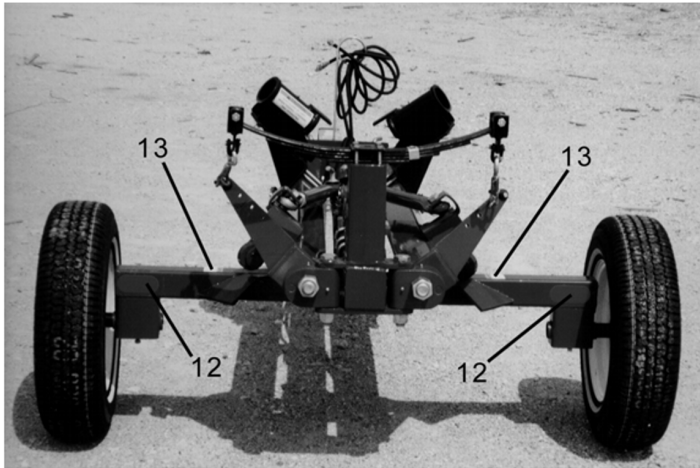

DL-RK-0002

NOTE: Rhino supplies safety decals on this product to promote safe operation. Damage to the decals may occur while in shipping, use, or reconditioning. Rhino cares about the safety of its customers, operators, and bystanders, and will replace the safety decals on this product in the field, free of charge (Some shipping and handling charges may apply). Contact your Rhino dealer to order replacement decals.

SAFETY

SAFETY

Decal Description

WARNING!- Multiple Hazard and General Safety

P/N 999200

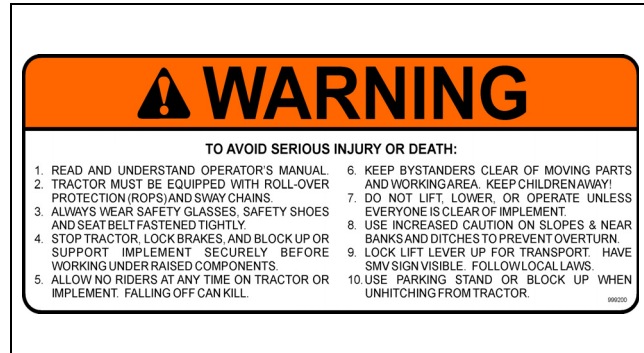

For safety and to guarantee optimum product reliability always use genuine RHINO replacement parts.

P/N 00760657



Operator's Manual (with repair parts) and warranty was attached to this implement during final inspection.

P/N 00763977



Peligro Translation, If you do not know how to read English, please find someone who knows how to read English.

P/N 00725746



SAFETY

WARNING! Multiple Hazard and General Safety

P/N 3048304

Logo Product Name: Rhino

P/N D302

Model Name - RC456

P/N 3048302

DANGER! Crushing and Pinch Points.

Moving machinery parts can pinch or crush or fall-which may cause injury or death.

P/N 02962765

⚠ WARNING!

1. Stay clear of cart when raising, lowering, and operating.
2. When using a new cylinder - first run cylinder in and out before mounting to cart. Air in the lines may result in lift mechanism dropping abruptly.
3. Before unfolding wings from transport position - be certain cylinder is properly installed and cart tongue is hitched to implement.
4. Use cart to carry original equipment only.
5. Never pull cart in transport position unless wings are folded to wing rest and pinned.
6. Failure to follow these warnings could result in injury or death.

3048304

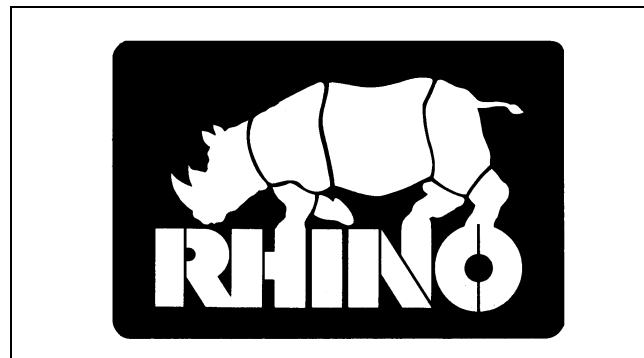

RC456

⚠ DANGER

CRUSHING AND PINCH POINTS

MOVING MACHINERY PARTS CAN PINCH OR CRUSH OR FALL-WHICH MAY CAUSE INJURY OR DEATH.

02962765

SAFETY

SAFETY

SAFETY

WARNING! Stay Clear of Cart

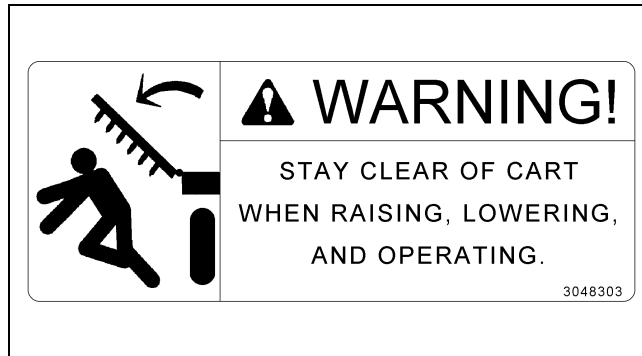

P/N 3048303

WARNING! Speed Restriction.

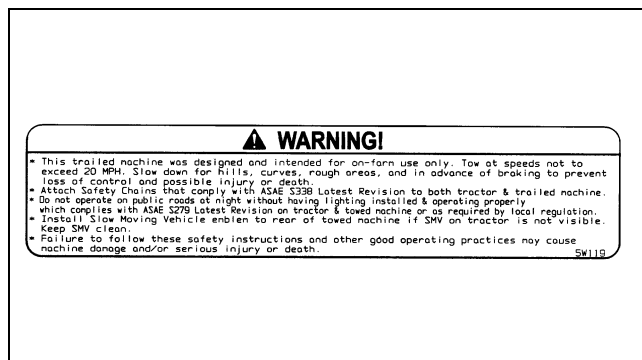

P/N 5W119

WARNING! Tractor rearing

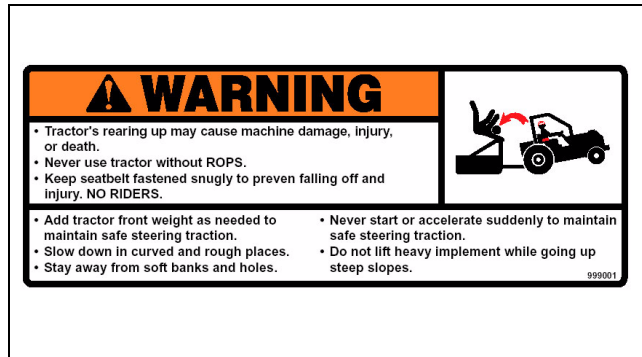

P/N 999001

Yellow Reflectors

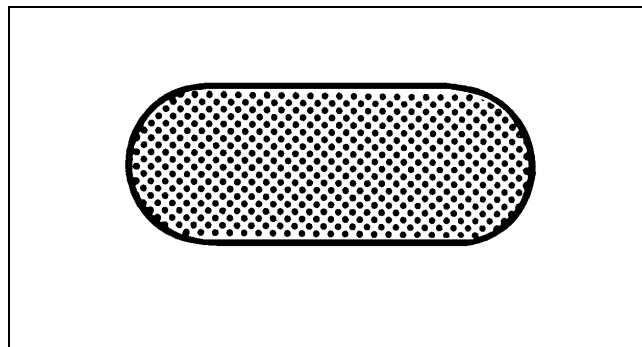

P/N 2738333

SAFETY

WARNING! Pinch Points

P/N 02962764



WARNING! Failure to INSPECT and REPAIR or REPLACE Hoses may allow worn Hoses to rupture SUDDENLY and VIOLENTLY with resulting serious BODILY INJURY from SCALDING or FIRE with resulting BURN INJURY or DEATH.

P/N 02965262



WARNING! Transport.

P/N 3668308

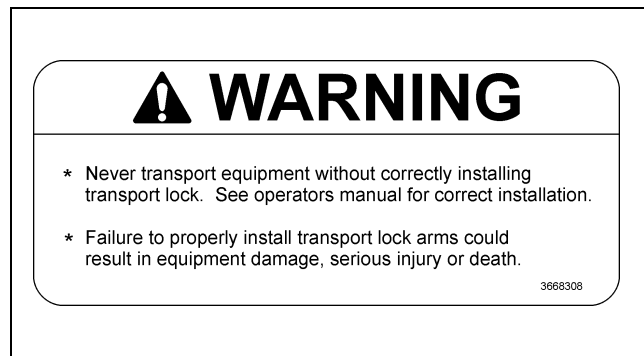

Slow Moving Vehicle Decal. Keep SMV reflector clean and visible. DO NOT transport or operate without the SMV.

P/N 03200347

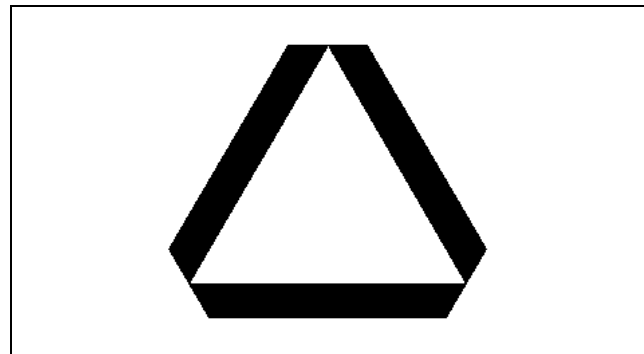

SAFETY

SAFETY

Federal Laws and Regulations

This section is intended to explain in broad terms the concept and effect of federal laws and regulations concerning employer and employee equipment operators. This section is not intended as a legal interpretation of the law and should not be considered as such.

Employer-Employee Operator Regulations

U.S. Public Law 91-596 (The Williams-Steiger Occupational and Health Act of 1970) OSHA

This Act Seeks:

"...to assure so far as possible every working man and woman in the nation safe and healthful working conditions and to preserve our human resources..."

DUTIES

Sec. 5 (a) Each employer-

- (1) shall furnish to each of his employees employment and a place of employment which are free from recognized hazards that are causing or are likely to cause death or serious physical harm to his employees;
- (2) shall comply with occupational safety and health standards promulgated under this Act.
- (b) Each employee shall comply with occupational safety and health standards and all rules, regulations and orders issued pursuant to this Act which are applicable to his own actions and conduct.

OSHA Training Requirements

Title 29, Code of Federal Regulations Part 1928.57(a)(6). www.osha.gov

Operator instructions. At the time of initial assignment and at least annually thereafter, the employer shall instruct every employee who operates an agricultural tractor and implements in the safe operating practices and servicing of equipment with which they are or will be involved, and of any other practices dictated by the work environment.

Keep all guards in place when the machine is in operation;

Permit no riders on equipment

Stop engine, disconnect the power source, and wait for all machine movement to stop before servicing, adjusting, cleaning or unclogging the equipment, except where the machine must be running to be properly serviced or maintained, in which case the employer shall instruct employees as to all steps and procedures which are necessary to safely service or maintain the equipment.

Make sure everyone is clear of machinery before starting the engine, engaging power, or operating the machine.

Employer Responsibilities:

To ensure employee safety during Tractor and Implement operation, it is the employer's responsibility to:

1. Train the employee in the proper and safe operation of the Tractor and Implement.
2. Require that the employee read and fully understand the Tractor and Implement Operator's manual.
3. Permit only qualified and properly trained employees to operate the Tractor and Implement.
4. Maintain the Tractor and Implement in a safe operational condition and maintain all shields and guards on the equipment.
5. Ensure the Tractor is equipped with a functional ROPS and seat belt and require that the employee operator securely fasten the safety belt and operate with the ROPS in the raised position at all times.
6. Forbid the employee operator to carry additional riders on the Tractor or Implement.
7. Provide the required tools to maintain the Tractor and Implement in a good safe working condition and provide the necessary support devices to secure the equipment safely while performing repairs and service.
8. Require that the employee operator stop operation if bystanders or passersby come within 300 feet.

Child Labor Under 16 Years of Age

Some regulations specify that no one under the age of 16 may operate power machinery. It is your responsibility to know what these regulations are in your own area or situation. (Refer to U.S. Dept. of Labor, Employment Standard Administration, Wage & Home Division, Child Labor Bulletin #102.)

INTRODUCTION SECTION

Introduction Section 2-1

INTRODUCTION

INTRODUCTION

This Wheel Rake Carrier is designed with care and built with quality materials by skilled workers. Proper assembly, maintenance, and operating practices, as described in this manual, will help the owner/operator get years of satisfactory service from the machine.

The purpose of this manual is to familiarize, instruct, and train. The Safety Section is a **MUST READ** section prior to any use of the rake. The Assembly Section instructs the owner/operator in the correct assembly of the Rake Carrier. Careful use and timely service saves extensive repairs and costly downtime losses. The Operation Section informs the owner/operator how to work the rake carrier and explains proper procedures and safe practices prior to and during the operation of the rake carrier. The Maintenance Section instructs the owner/operator of all the necessary inspection, lubrication, general maintenance needed to insure long life and trouble free operation of your carrier.

Safety is of primary importance to the owner/operator and to the manufacturer. The first section of this manual includes a list of Safety Messages, that, if followed, will help protect the operator and bystanders from injury or death. Many of the Safety Messages will be repeated throughout the manual. The owner/operator/dealer should know these Safety Messages before assembly and be aware of the hazards of operating this rake during assembly, use, and maintenance. The Safety Alert Symbol combined with a Signal Word, as seen below, is intended to warn the owner/operator of impending hazards and the degree of possible injury faced when operating this machine.



Indicates an imminently hazardous situation that, if not avoided, **WILL** result in **DEATH OR VERY SERIOUS INJURY**.



Indicates an imminently hazardous situation that, if not avoided, **COULD** result in **DEATH OR SERIOUS INJURY**.



Indicates an imminently hazardous situation that, if not avoided, **MAY** result in **MINOR INJURY**.

Important

Identifies special instructions or procedures that, if not strictly observed, could result in damage to, or destruction of the machine, attachments or the environment.

INTRODUCTION



FC-RK-0002

INTRODUCTION

The Rhino Wheel Rake Carrier has been engineered and built for ease of operation and long service life. The Rhino RC456 Rake Carrier has been designed to transport and operate a pair of 4 Wheel, 5 Wheel, or 6 Wheel Rakes in a V-Type configuration. With a reasonable amount of preventive maintenance, your Rake Carrier will provide years of dependable service.

It is important that you thoroughly understand the operation of the wheel rake carrier before use. Read through this manual completely, watching especially for safety symbols which will alert you to possible hazards.

INTRODUCTION

Attention Owner/Operator

BEFORE OPERATING THIS MACHINE:

1. Carefully read the Operator's Manual, completely understand the Safety Messages and instructions, and know how to operate correctly both the tractor and rake carrier.
2. Fill out the Warranty Card in full. Be sure to answer all questions, including the Serial Number of the Mower. Mail within 30 days of delivery date of this implement.

NOTE: Warranties are honored only if completed "Owner Registration and Warranty" forms are received by Alamo Group within thirty days of delivery of the implement.

3. Record the Rake Carrier Model and Serial Numbers on the Warranty page at the front of the Operator's Manual. Keep this as part of the permanent maintenance file for the Rake Carrier.

IMPORTANT

For your safety and to guarantee optimum product reliability, always use Genuine RHINO replacement parts. The use of inferior "will-fit" parts will void Warranty of your RHINO implement and may cause premature or catastrophic failure which can result in serious injury or death. If you have any questions concerning the repair parts you are using, contact Rhino, 1020 S. Sangamon Ave., Gibson City, Illinois 60936 A Member of Alamo Group



ASSEMBLY SECTION

Assembly Section 3-1

ASSEMBLY

GENERAL INSTRUCTIONS

Assembly must be done carefully and accurately, for the safety of the person(s) doing the assembling and to ensure proper machine operation.

Assembly should be done on a flat, solid surface, using the proper tools and wearing suitable clothing, making sure that all people not involved in the assembly be kept at a safe distance.

Assemblers must provide suitable lifting mechanisms and supports for stabilizing the partially assembled units, so as to prevent them from falling and causing damage or injury.

The steps for assembly are illustrated in following. Depending on the experience of the assemblers and the tools available, it is not necessary that the instructions be followed in the exact order given here, but the safety precautions described above must always be followed carefully and scrupulously.



Before beginning operations, read the instruction manual carefully.



Before doing any maintenance or repair work, stop the machine at a suitable spot. Turn off the tractor engine, apply the brake, remove the key from the ignition and consult this manual.



This is a warning to use proper accident protection when carrying out maintenance and repairs.



Indicates an impending dangerous situation which, if not avoided, will cause death or severe personal injury.



Indicates a potentially dangerous situation which, if not avoided, could cause death or severe personal injury, including dangers which are present when protection is removed.



Indicates a potentially dangerous situation which, if not avoided, can provoke less severe or minor injuries.

WARNING

TO AVOID SERIOUS INJURY OR DEATH:

1. READ AND UNDERSTAND OPERATOR'S MANUAL.
2. TRACTOR MUST BE EQUIPPED WITH ROLL-OVER PROTECTION (ROPS) AND SWAY CHAINS.
3. ALWAYS WEAR SAFETY GLASSES, SAFETY SHOES AND SEAT BELT FASTENED TIGHTLY.
4. STOP TRACTOR, LOCK BRAKES, AND BLOCK UP OR SUPPORT IMPLEMENT SECURELY BEFORE WORKING UNDER RAISED COMPONENTS.
5. ALLOW NO RIDERS AT ANY TIME ON TRACTOR OR IMPLEMENT. FALLING OFF CAN KILL.
6. KEEP BYSTANDERS CLEAR OF MOVING PARTS AND WORKING AREA. KEEP CHILDREN AWAY!
7. DO NOT LIFT, LOWER, OR OPERATE UNLESS EVERYONE IS CLEAR OF IMPLEMENT.
8. USE INCREASED CAUTION ON SLOPES & NEAR BANKS AND DITCHES TO PREVENT OVERTURN.
9. LOCK LIFT LEVER UP FOR TRANSPORT. HAVE SMV SIGN VISIBLE. FOLLOW LOCAL LAWS.
10. USE PARKING STAND OR BLOCK UP WHEN UNHITCHING FROM TRACTOR.

998200

ASSEMBLY

ASSEMBLY INSTRUCTIONS

1. Layout and identify all parts. Many parts will be partially assembled by the manufacturer. The main frame and swing arms are already assembled, along with the tension spring and adjustment chains, and the hydraulic cylinder is installed by the manufacturer. The spindles and hubs are also installed on the axle.
2. Support the main frame assembly on sturdy stands and install the axle assembly under the main frame. Measure from the rear of the main frame 17" to 18" to the back side of the axle tube. Secure the axle with three 4" x 5 1/2" x 5/8" U-Bolts, lockwashers, and nuts. **Figure Asm-RK-0160**

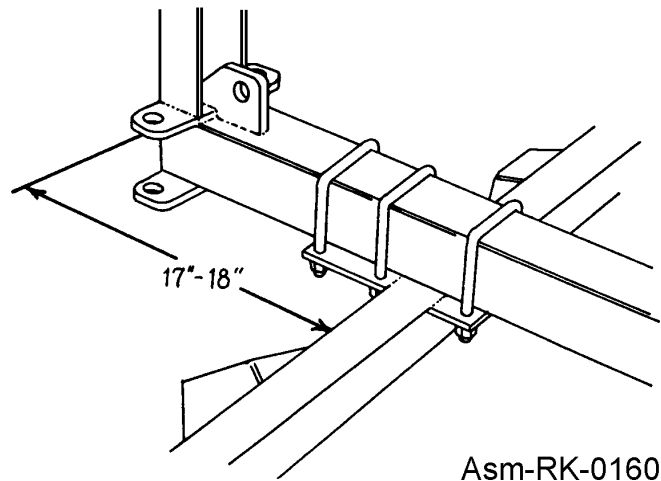

3. The axle may need to be moved forward or backward until the caster wheels on the wings roll in the proper location on the axle ramps (See Illustration 2). Tighten the U-Bolts when axle is properly located. **Figure Asm-RK-0161**

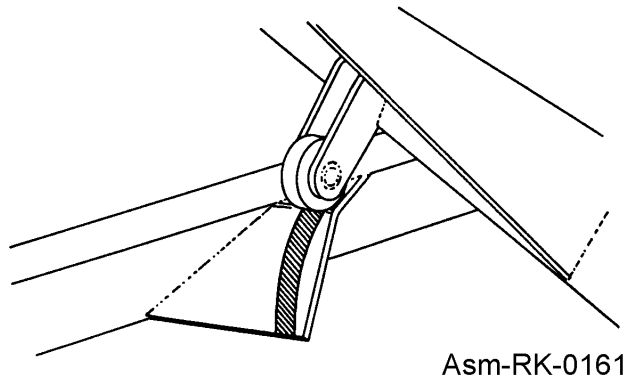

4. Install the tongue on the main frame using three 5/8" x 2" bolts, nuts, and lockwashers. On some models, a reinforcing plate is used. If so, install the plate beneath the tongue and main frame using six 1/2" x 1 1/2" bolts, nuts, and lockwashers. Install a hose support on the top bolt as the tongue is installed. If the optional extended tongue is used, install the extension between the main frame and tongue using the bolts provided and install a second reinforcing plate if used.
5. Install the threaded rod hose holder in the threaded hole on top of the tongue. Install a 1/2" jam nut on the rod before installing. Tighten the jam nut after the rod is position.
6. Install the support jack on the tongue using the pin supplied.
7. Install the tire on the wheel rims supplied and install the rims on the hubs. Torque the four lug bolts on each wheel to 75 Ft-Lbs.

Note: The height of the tires used will effect the operation of the wheel rakes. It is recommended that 195 x 14" tires be used.

ASSEMBLY

- Two hydraulic hoses, 1/4" x 188" and one 1/4" x 192" are included. Connect the longer hose to the rear port of the cylinder using a 90° elbow. Connect the shorter hose to the front port using a 90° elbow. Route the hoses through the hose holder on the tongue. Install the restrictor swivel on the male end of one hose. When the cylinder is replaced or reinstalled, the ports must go to the left side of the carrier when facing forward.

Important: Do not operate without restrictor installed.

- Before installing hydraulic lines, check for foreign material in lines. Keep hoses and fittings clean at all times. Be sure all connections are properly sealed to avoid leakage.



Do not exceed manufacturers maximum hydraulic system pressure at 2500 psi.

If the optional tongue extension is used, install the two 1/4" x 48" hoses included in the kit on the 188" and 192" hoses using the 1/2" NPT couplers provided. Install the restrictor fitting on the end of one extension hose.



Always wear protective eye goggles and use a magnifying glass or hold a piece of wood on suspected leaks. Pinhole hydraulic leaks can penetrate skin. Do not touch.

Note: If fluid penetrates the skin, it must be surgically removed within a few hours by a doctor familiar with the form of injury or gangrene may result. Make sure the weight of the machine has been taken off the hydraulic cylinder before disconnecting hydraulic hoses.

- Install the hose holder on the tongue center just forward of the cylinder using a capscrew and lockwasher. Secure the hoses on the holder with the clip, capscrew, lockwasher, and nut.
- Install the rake mount assemblies on the wings, as shown, using two U-bolts, nuts, and lockwashers to secure each assembly.

Note: Left and right mounting heads are used. Check for proper identification of left and right mounting heads.

Measure from the front edge of the wing to the center of the rake mount to determine the approximate location of the rake.

These settings are only approximate settings. The final position on the wing is determined by the desired width of the windrow. Moving the rake mounts forward on the wing makes the windrow wider. Moving the rake mounts rearward makes the windrow narrower.

| | |
|---------------|-----|
| 4 Wheel Rakes | 35" |
| 5 Wheel Rakes | 25" |
| 6 Wheel Rakes | 13" |

- Install the wheel rakes on the mount tube by inserting the rakes main frame tube into the tubes on the rake mounts. This operation can be made easier if the carrier is connected to the tractor tongue, hydraulics are connected and the wings are extended. Install the clamps on the rake tubes. Tighten the 1/2" x 1 1/2" bolts, nuts, and lockwashers snugly. The ears at the top of the clamp should be on either side of the tab on the mount tube so the rake can "float" as it works.

ASSEMBLY

Important: When the rake is positioned correctly, drill a hole through the clamp and the rake tube and install a 5/16" shear bolt, lockwasher, and nut. Figure Asm-RK-0162

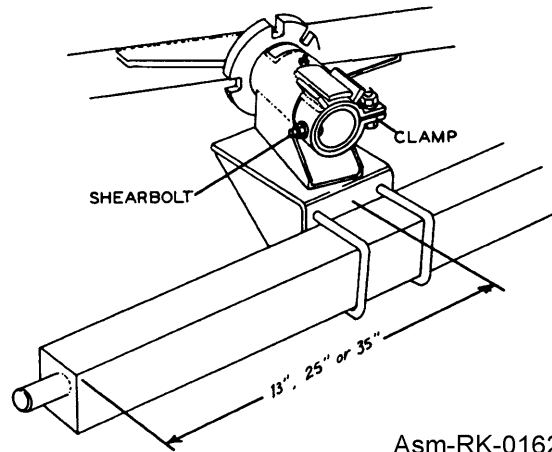

Asm-RK-0162

Note: Before operating this machine, lubrication of specific parts must be completed. Check tightness of lug bolts and spindle setscrews.

ASSEMBLY

OPERATION SECTION

Operation Section 4-1

OPERATION

RC456 WHEEL RAKE CARRIER OPERATION INSTRUCTIONS

Rhino wheel rake carriers are manufactured with quality material by skilled workers.

It is the operator's responsibility to be knowledgeable of all potential operating hazards and to take every reasonable precaution to ensure oneself, others, animals, and property are not injured or damaged by the rake carrier, rake, tractor, or a thrown object. Do not operate the rake if passersby, pets, livestock, or property are directly in front or to the rear of the unit.

This section is designed to familiarize, instruct, and educate safe and proper rake use to the operator. Pictures in this section are for the purpose of explaining the operation of a rake carrier and are not necessarily of a RC456 rake carrier. Some pictures may show shields removed for purposes of clarity. NEVER OPERATE this implement or tractor without all shields in place and in good operational condition. The operator must be familiar with rake carrier, rake and tractor operation and all associated safety practices before operating the rake and tractor. Proper operation of the RC456 carrier and rake, as detailed in this manual, will help ensure years of safe and satisfactory use of the implement.

IMPORTANT: To avoid rake damage, retorque all bolts after the first 10 hours of operation.

READ AND UNDERSTAND THE ENTIRE OPERATING INSTRUCTIONS AND SAFETY SECTION OF THIS MANUAL AND THE TRACTOR MANUAL BEFORE ATTEMPTING TO USE THE TRACTOR AND IMPLEMENT. If you do not understand any of the instructions, contact your nearest authorized dealer for a full explanation. Pay close attention to all safety signs and safety messages contained in this manual and those affixed to the implement and tractor. *OPS-U- 0001*

READ, UNDERSTAND, and FOLLOW the following Safety Messages. Serious injury or death may occur unless care is taken to follow the warnings and instructions stated in the Safety Messages. Always use good common sense to avoid hazards. (SG-2)



OPERATION

1. OPERATOR REQUIREMENTS

Safe operation of the unit is the responsibility of a qualified operator. A qualified operator has read and understands the implement and tractor Operator's Manuals and is experienced in implement and tractor operation and all associated safety practices. In addition to the safety messages contained in this manual, safety signs are affixed to the implement and tractor. If any part of the operation and safe use of this equipment is not completely understood, consult an authorized dealer for a complete explanation.

If the operator cannot read the manuals for themselves or does not completely understand the operation of the equipment, it is the responsibility of the supervisor to read and explain the manuals, safety practices, and operating instructions to the operator.

Safe operation of equipment requires that the operator wear approved Personal Protective Equipment (PPE) for the job conditions when attaching, operating, servicing, and repairing the equipment. PPE is designed to provide operator protection and includes the following safety wear:

PERSONAL PROTECTIVE EQUIPMENT (PPE)

- Always Wear Safety Glasses
- Hard Hat
- Steel Toe Safety Footwear
- Gloves
- Hearing Protection
- Close Fitting Clothing
- Respirator or Filter Mask (depends on operating conditions) OPS-U- 0002

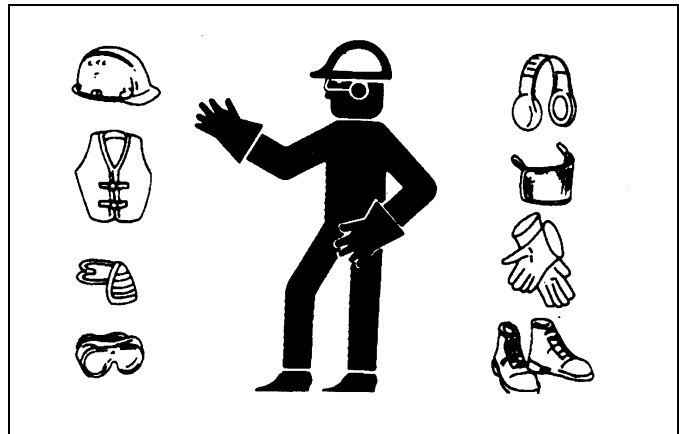

⚠ DANGER

DO NOT use drugs or alcohol immediately before or while operating the Tractor and Implement. Drugs and alcohol will affect an operator's alertness and coordination and therefore affect the operator's ability to operate the equipment safely. Before operating the Tractor or Implement, an operator on prescription or over-the-counter medication must consult a medical professional regarding any side effects of the medication that would hinder their ability to operate the Equipment safely. NEVER knowingly allow anyone to operate this equipment when their alertness or coordination is impaired. Serious injury or death to the operator or others could result if the operator is under the influence of drugs or alcohol. (SG-27)

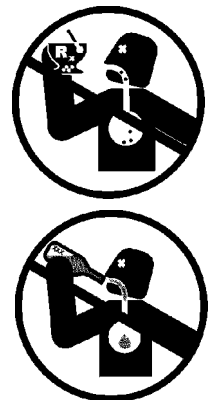

OPERATION

2. TRACTOR REQUIREMENTS

The tractor used to operate the implement must have the power capacity to lift, pull, and operate the Power Take Off (PTO) at the implement's rated speed while traveling at a ground speed between 2 and 5 MPH. Operating the implement with a tractor that does not meet the following requirements may cause tractor or implement damage and be a potential danger to the operator and passersby.

Tractor Requirements and Capabilities

- ASABE approved Roll-Over Protective Structure (ROPS) or ROPS cab and seat belt.
- Tractor Safety Devices Slow Moving Vehicle (SMV) emblem, lighting, PTO master shield
- Tractor Horsepower-Minimum 30 HP

2.1 ROPS and Seat Belt

The tractor must be equipped with a Roll-Over-Protective-Structure (ROPS) (tractor cab or roll-bar) and seat belt to protect the operator from falling off the tractor, especially during a roll over where the driver could be crushed and killed. Only operate the tractor with the ROPS in the raised position and seat belt fastened. Tractor models not equipped with a ROPS and seat belt should have these life saving features installed by an authorized dealer. *OPS-U- 0003*



Operate this Equipment only with a Tractor equipped with an approved roll-over-protective system (ROPS). Always wear seat belts. Serious injury or even death could result from falling off the tractor--particularly during a turnover when the operator could be pinned under the ROPS. (SG-7)



2.2 Tractor Safety Devices

If transporting or operating the tractor and implement near a public roadway, the tractor must be equipped with proper warning lighting and a Slow Moving Vehicle (SMV) emblem which are clearly visible from the rear of the unit. Lights and a SMV emblem must be equipped directly on implements if the visibility of the tractor warning signals are obscured.

Maintain all manufacturer equipped safety shields and guards. Always replace shields and guards that were removed for access to connect, service, or repair the tractor or implement. Never operate the tractor PTO with the PTO master shield missing or in the raised position. *OPS-U- 0004*

2.3 Tractor Horsepower

The horsepower required to operate the rake depends on many factors including type of vegetation to be raked, terrain condition, operator experience, and condition of the implement and tractor. For most raking condition, the ER rakes require a tractor with at least 30 HP. Operating the implement with a tractor that does not have adequate power may damage the tractor engine.

OPERATION

3. GETTING ON AND OFF THE TRACTOR

Before getting onto the tractor, the operator must read and completely understand the implement and tractor operator manuals. If any part of either manual is not completely understood, consult an authorized dealer for a complete explanation. *OPS-U- 0007*



WARNING

Do not mount or dismount the Tractor while the tractor is moving. Mount the Tractor only when the Tractor and all moving parts are completely stopped. (SG-12)



3.1 Boarding the Tractor

Use both hands and equipped handrails and steps for support when boarding the tractor. Never use control levers for support when mounting the tractor. Seat yourself in the operator's seat and secure the seat belt around you.

Never allow passengers to ride on the tractor or attached equipment. Riders can easily fall off and be seriously injured or killed from falling off and being ran over. It is the operator's responsibility to forbid all extra riders at all times. *OPS-U- 0008*



DANGER

Never allow children to operate, ride on, or come close to the Tractor or Implement. Usually, 16-17 year-old children who are mature and responsible can operate the implement with adult supervision, if they have read and understand the Operator's Manuals, been trained in proper operation of the tractor and Implement, and are physically large enough to reach and operate the controls easily. (SG-11)



DANGER

Never allow children or other persons to ride on the Tractor or Implement. Falling off can result in serious injury or death. (SG-10)



3.2 Dismounting the Tractor

Before dismounting, park the tractor and implement on a reasonably level surface, apply the parking brake, idle the engine down, disengage the PTO, and lower the implement to the ground. Shut down the tractor engine according to the operator's manual, remove the key, and wait for all motion to completely stop. Never leave the seat until the tractor, its engine and all moving parts have come to a complete stop.

Use hand rails and steps when exiting the tractor. Be careful of your step and use extra caution when mud, ice, snow or other matter has accumulated on the steps or hand rails. Use all handrails and steps for support and never rush or jump off the tractor. *OPS-U- 0009*

OPERATION

4. STARTING THE TRACTOR

The operator must have a complete understanding of the placement, function, and operational use of all tractor controls before starting the tractor. Review the tractor operator's manual and consult an authorized dealer for tractor operation instructions if needed.

Essential Tractor Controls:

- Locate the light control switch.
- Locate the engine shut off control.
- Locate the brake pedals and the clutch.
- Locate the PTO control.
- Locate the 3-point hitch control lever.
- Locate the hydraulic remote control levers.

Before starting the tractor ensure the following:

- Conduct all pre-start operation inspection and service according to the tractor operator's manual.
- Make sure all guards, shields, and other safety devices are securely in place.
- The parking brake is on.
- The PTO control lever is disengaged.
- The 3-point hitch control lever is in the lowered position.
- The hydraulic remote control levers are in the neutral position.
- The tractor transmission levers are in park or neutral.

Refer to the tractor owner's manual for tractor starting procedures. Only start the tractor while seated and belted in the tractor operator's seat. Never bypass the ignition switch by short circuiting the starter solenoid.

After the tractor engine is running, avoid accidental contact with the tractor transmission to prevent sudden and unexpected tractor movement. *OPS-U-0028*



Never run the Tractor engine in a closed building or without adequate ventilation. The exhaust fumes can be hazardous to your health. (SG-23)



Start tractor only when properly seated in the Tractor seat. Starting a tractor in gear can result in injury or death. Read the Tractor operators manual for proper starting instructions. (SG-13)



OPERATION

5. CONNECTING THE IMPLEMENT TO THE TRACTOR

Use extreme caution when connecting the implement to the tractor. The implement should be securely resting at ground level or setting on blocks. Keep hands and feet from under the implement and clear of pinch points between the tractor hitch arms and implement pins. *OPS-U-0038*



Always shut the Tractor completely down, place the transmission in park, and set the parking brake before you or anyone else attempts to connect or disconnect the Implement and Tractor hitches. (S3PT-15)



Make sure a restrictor is installed on one of the hydraulic lines. Failure to use a restrictor will allow the machine to fold and unfold rapidly and could result in damage to the machine, and injury to bystanders.

6. SETTING THE IMPLEMENT

Connect the machine to the tractor tongue using a 3/4" hitch pin with a retaining clip. The adjustable jack will allow the tongue to be raised or lowered during hookup. After hookup to the tractor, store the jack in the horizontal position.

6.1 Hydraulics

1. Connect the hydraulic inlet and outlet hoses to the tractor hydraulic system.



Make sure a restrictor is installed on one of the hydraulic lines. Failure to use a restrictor will allow the machine to fold and unfold rapidly and could result in damage to the machine, and injury to bystanders.

2. To lower the rakes to the working position, pull the transport pins for each wing and apply hydraulic pressure to retract the cylinder. The wings will spread apart and the rake will lower to the working position as the castor wheels move down the axle ramps. The transport pins can be store in the raised position by installing clips in upper holes.



Operate the hydraulic cylinder through the cycle a few times to expel all air through the system. Failure to fully charge the hydraulic system could result n injury when the rakes fall abruptly to the ground.



Make sure the area around the machine is clear before lowering. Do not lower rakes when people or pets are near the rakes or folding mechanism.



On a fully-assembled unit, do not remove the Wing Retaining Strap until hoses are attached to the tractor and the Wing Cylinders are filled with oil. Lower the Wings slowly and carefully. Keep bystanders away during operations. (STI-05)

OPERATION

⚠ DANGER

DO NOT allow any person under a folded wing unless wing is securely locked up or supported. **DO NOT** approach the Implement unless the Tractor is turned off and all motion has ceased. Never work under the frame work, or any lifted component unless the implement is securely supported or blocked up. A sudden or inadvertent fall by any of these components could cause serious injury or even death. (STI-03)



⚠ WARNING

Use extreme care when lowering or unfolding the implement's wings. Make sure no bystanders are close by or underneath the wings. Allow ample clearance around the implement when folding or unfolding the wings. Use extreme caution around buildings or overhead power lines. (S3PT-05)

OPERATION

6.2 Setting the Rake

1. Set the rake angle by repositioning the 5/8" bolt in the rake mounting bracket. Six holes are available for adjustments.

Note: See the rake operator's manual for more information on setting the rakes.

2. Working speed is normally 5 to 10 mph. Speed varies with different hay conditions for terrain.

Note: Consult the rake operator's manual for complete operation instructions.

3. To raise the rakes, apply hydraulic pressure to extend the hydraulic cylinder. When the wings are in the retracted position, install the transport pins in the frame to lock the wings in place.

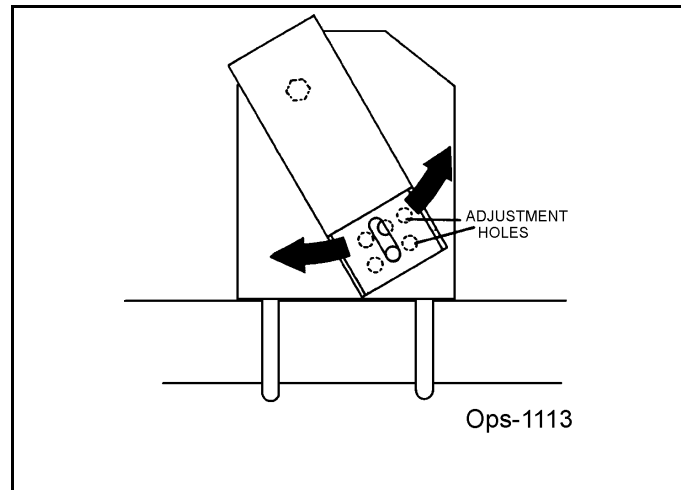

6.3 Wing Adjustment

The wings must be adjusted so that both wings retract into the transport position at approximately the same time. With the rakes removed from the wings, disconnect the adjustable link between the sliding cylinder mount and the left wing. Clear the area around the machine and extend the cylinder until the right wing just retracts into the lock position. Manually retract the left arm to the same position and adjust the link until the pin drops into the pivot point. Turning the threaded rod end "in" will cause the wing to move towards the tongue. Secure the pin when the adjustment is complete.

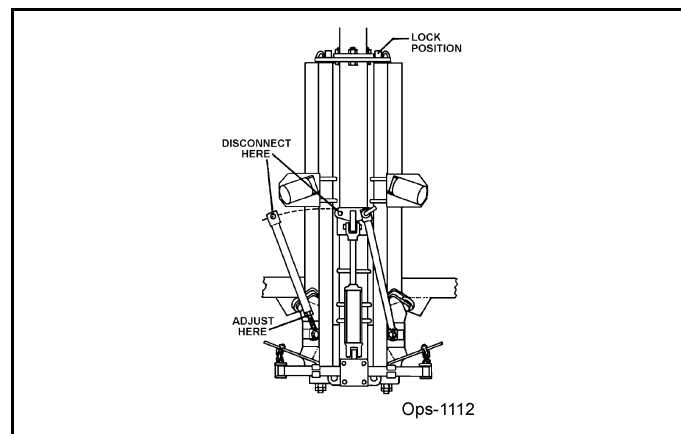

OPERATION

CAUTION

The linkage can be adjusted with the rakes installed ONLY if the left wing is locked in the transport position. If the wing is allowed to extend to the point where the caster wheel is on the axle ramp, the rake can fall rapidly and possibly cause an injury.

6.4 Adjusting Ground Pressure

1. When set properly, individual rake wheels should be light enough to float over the ground while maintaining a constant ground speed. Each adjustable chain is equipped with a threaded rod that is used to balance weight of the left and right side, and to make any fine adjustments. The chain has three flexible links. If the illustrated settings do not flatten or bow down the leaf spring as shown, then relocate the clevis on the second chain link and readjust.

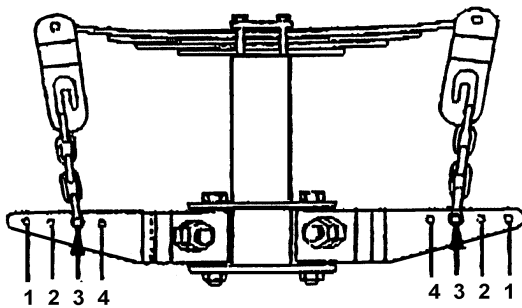

8 WHEEL RAKE SETTINGS

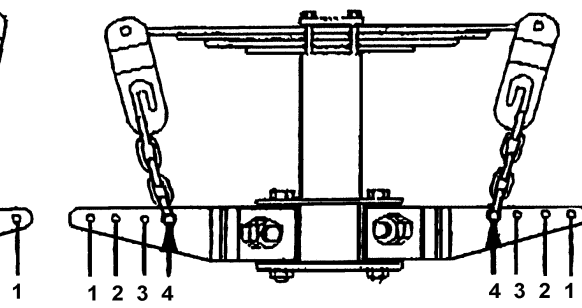

The chain clevis should be in holes 3 or 4 with the leaf spring slightly bowed up or flat.

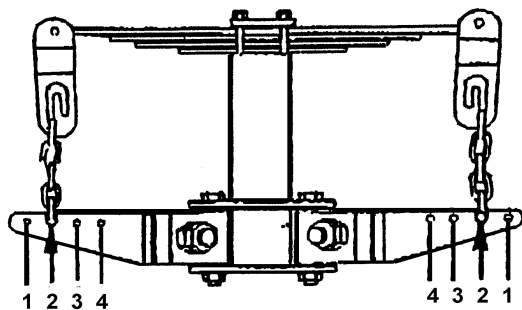

10 WHEEL RAKE SETTINGS

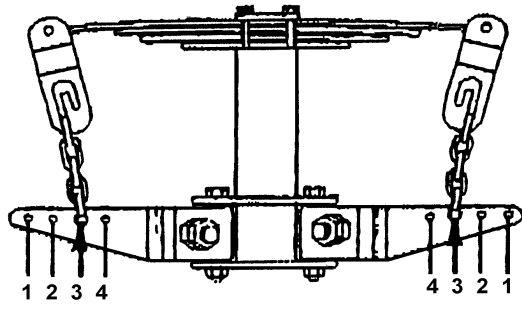

The chain clevis should be in holes 2 or 3 with the leaf spring flat or bowed slightly.

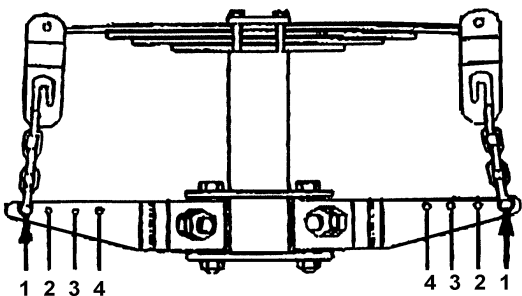

12 WHEEL RAKE SETTINGS

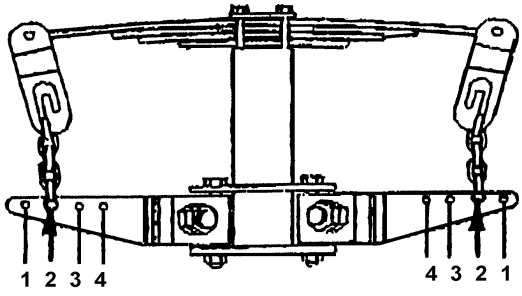

The chain clevis should be in holes 1 or 2 with the leaf spring bowed down slightly to bowed down.

Ops-1110

OPERATION

OPERATION

- The threaded rod in the adjustable link should be adjusted so that no more than 3/4" of threads are showing.

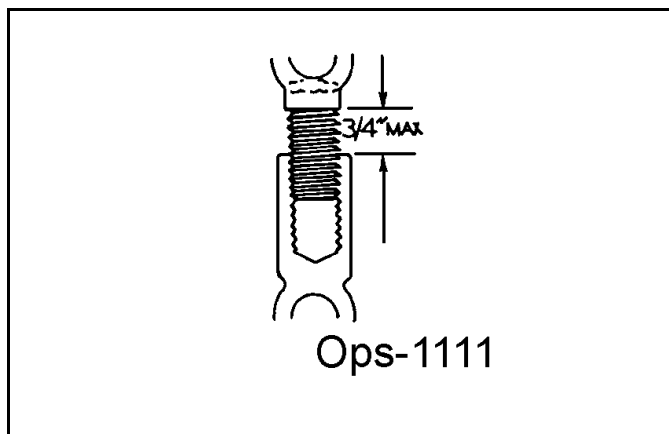

CAUTION

Never try to adjust spring tension with the rake in the working position. Raise the rakes to the transport position before making adjustments. Failure to do so could result in serious injury.

- The width of the windrow can be adjusted by moving one or both rakes forward or backward on the wings. To do this, loosen the U-Bolts securing the rake mounts and reposition the mounts. Moving the mounts forward will widen the windrow. Moving the mounts back will make the windrow narrow. Extend the wings and check for clearance around the tires before operating.
- When one rake is to be used alone, leave the locking pin in place on the wing not used and pull the pin securing the linkage between the sliding cylinder mount and the unused wing. The operation of the remaining rake is not affected.

7. PRE-OPERATION INSPECTION AND SERVICE

Before each use, a pre-operation inspection and service of the implement and tractor must be performed. This includes routine maintenance and scheduled lubrication, inspecting that all safety devices are equipped and functional, and performing needed repairs. DO NOT operate the unit if the pre-operation inspection reveals any condition affecting safe operation. Perform repairs and replacement of damaged and missing parts as soon as noticed. By performing a thorough pre-operation inspection and service, valuable down time and repair cost can be avoided. OPS-U-0029

DANGER

Never work under the Implement, the framework, or any lifted component unless the Implement is securely supported or blocked up to prevent sudden or inadvertent falling which could cause serious injury or even death. (SG-14)



OPERATION

WARNING

Periodically inspect all moving parts for wear and replace when necessary with authorized service parts. Look for loose fasteners, worn or broken parts, and leaky or loose fittings. Make sure all pins have cotter pins and washers. Serious injury may occur from not maintaining this machine in good working order. (SG-21)

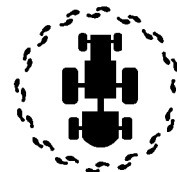

OPERATION

7.1 Tractor Pre-Operation Inspection/Service

Refer to the tractor operator's manual to ensure a complete pre-operation inspection and scheduled service is performed according to the manufacturers recommendations. The following are some of the items that require daily service and inspection:

- Tire condition/air pressure
- Wheel lug bolts
- Steering linkage
- PTO shield
- SMV sign is clean and visible
- Tractor's lights are clean and functional
- Tractor Seat belt is in good condition
- Tractor ROPS is in good condition
- ROPS is in the raised position
- No tractor oil leaks
- Radiator free of debris
- Engine oil level and condition
- Engine coolant level and condition
- Power brake fluid level
- Power steering fluid level
- Fuel condition and level
- Sufficient lubrication at all lube points
- Air filter condition *OPS-U-0030*



7.2 Rake Pre-Operation Inspection/Service

Before each rake use, a complete inspection and service is required to ensure the rake is in a good and safe working condition. Damaged and/or broken parts should be repaired and/or replaced immediately. To ensure the rake is ready for operation, conduct the following. *OPS-RK-0001*

OPERATION

OPERATION

The operator's manual and safety signs affixed on the unit contain important instructions on the safe and proper use of the equipment. Maintain these important safety features on the implement in good condition to ensure the information is available to the operator at all times.

- Ensure the manual canister is secured to the equipment with the operator's manual inside.
- Ensure all safety signs are in place and legible. Replace missing, damaged, and illegible decals. *OPS-U-0011*



MAINFRAME ASSEMBLY

- Inspect condition of frame weldment.
- Ensure all bolts and screws are in position and are properly torqued.
- Ensure all pins are in place and fastened with screws.
- Ensure frame is properly mounted to tractor and hardware is properly installed and tightened. *OPS-RK-0003*

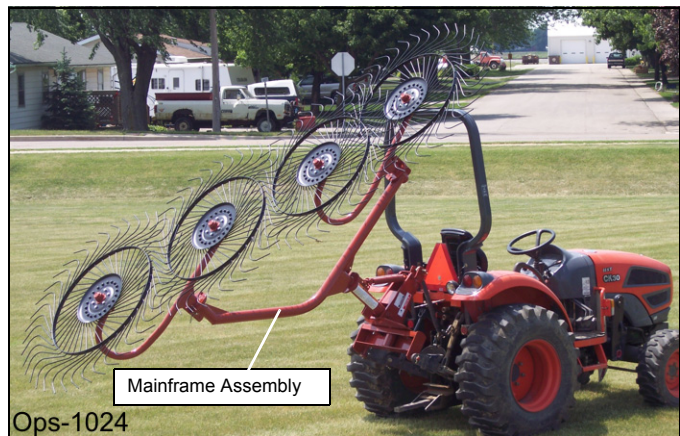

HYDRAULIC LINE INSPECTION

- Check for hydraulic leaks along hoses, cylinders and fittings. **IMPORTANT: DO NOT use your hands to check for oil leaks. Use a piece of heavy paper or cardboard to check for hydraulic oil leaks.**
- Make sure hydraulic cylinders are in good condition.
- Make sure hydraulic cylinder pins are in place and retained. *OPS-RK-0002*

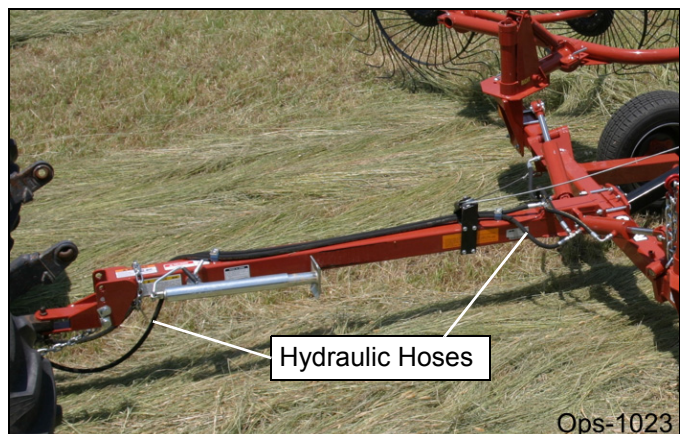

OPERATION

WARNING

Do not operate this Equipment with hydraulic oil or fuel leaking. Oil and fuel are explosive and their presence could present a hazard. Do not check for leaks with your hand! High-pressure oil streams from breaks in the line could penetrate the skin and cause tissue damage including gangrene. To check for a hose leak, SHUT the unit ENGINE OFF and remove all hydraulic pressure. Wear oil impenetrable gloves, safety glasses and use Cardboard to check for evidence of oil leaks. If you suspect a leak, REMOVE the HOSE and have it tested at a Dealer. If oil does penetrate the skin, have the injury treated immediately by a physician knowledgeable and skilled in this procedure. (SG-15)



- Inspect teeth for looseness, breakage and excessive wear. Make sure implement is on the ground and securely blocked up. Replace damaged, worn, and missing teeth at the same time to maintain uniform tine height.
- Remove any hay or other debris which may be wrapped around the teeth.
- Inspect condition of all hardware. OPS-RK-0004

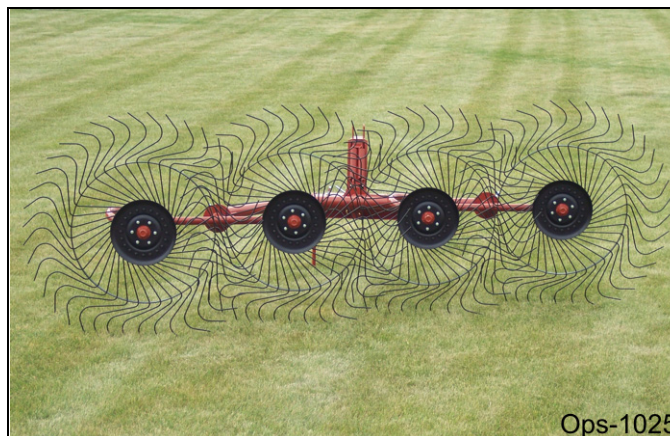

Ops-1025

- Perform scheduled lubrication as detailed in the maintenance section.
- Check for corrosion in storage.
- Inspect that the 3-point hitch pins are the proper size, correctly installed, and secured to the tractor lift arms with retaining pins inserted.
- Make sure tires and wheel are in good condition. Make sure the wheel lug nuts are tight. OPS-RK-0005



Ops-1026

OPERATION

Tractor PRE-OPERATION Inspection



Tractor ID# _____ Make _____

Date: _____ Shift _____



Before conducting the inspection, make sure the tractor engine is off, all rotation has stopped and the tractor is in park with the parking brake engaged. Make sure the mower is resting on the ground or securely blocked up and all hydraulic pressure has been relieved.

OPERATION

| Item | Condition at Start of Shift | Specific Comments if not O.K. |
|--|-----------------------------|-------------------------------|
| The flashing lights function properly | | |
| The SMV Sign is clean and visible | | |
| The tires are in good condition with proper pressure | | |
| The wheel lug bolts are tight | | |
| The tractor brakes are in good condition | | |
| The steering linkage is in good condition | | |
| There are no visible oil leaks | | |
| The hydraulic controls function properly | | |
| The ROPS or ROBS Cab is in good condition | | |
| The seatbelt is in place and in good condition | | |
| The 3-point hitch is in good condition | | |
| The drawbar pins are securely in place | | |
| The PTO master shield is in place | | |
| The engine oil level is full | | |
| The brake fluid level is full | | |
| The power steering fluid level is full | | |
| The fuel level is adequate | | |
| The engine coolant fluid level is full | | |
| The radiator is free of debris | | |
| The air filter is in good condition | | |

Operator's Signature: _____

DO NOT OPERATE an UNSAFE TRACTOR or MOWER

OPERATION

HAY RAKE PRE-OPERATION Inspection



Rake ID# _____ Make _____

Date _____ Shift _____



Before conducting the inspection, make sure the Tractor engine is off, all rotation has stopped and the tractor is in park position with the parking brake engaged. Make sure the Rake arms is resting on the ground or securely blocked up and all hydraulic pressure has been relieved.

OPERATION

| Item | Condition at Start of Shift | Specific Comments if not O.K. |
|---|-----------------------------|-------------------------------|
| REAR RAKE OR BOX RAKE | | |
| The Operator's Manual is in the Canister on the Hay Rake | | |
| All Safety Decals are in place and legible | | |
| The Tongue/Hitch connection bolts & pins are tight | | |
| There are no cracks in Tongue or Hitch | | |
| There are no cracks in Loader Arms or Mounts | | |
| The Tow chain is secured to the Tractor & Hay Rake | | |
| The Wing connection bolts & pins are tight | | |
| Transport locks and retaining chains are in good condition | | |
| Rake spokes are in good condition and securely attached to wheels | | |
| Rake wheels are securely attached to the frame members | | |
| The Hydraulic Cylinders are in good condition | | |
| The Hydraulic Cylinder pins are in place & retained | | |
| There are no leaking or damaged hoses | | |
| There is no evidence of Hydraulic leaks | | |
| The tires and wheel(s) are in good condition | | |
| Wheel lug nuts are tight | | |

Operator's Signature: _____

DO NOT OPERATE an UNSAFE TRACTOR or IMPLEMENT

OPERATION

8. DRIVING THE TRACTOR AND IMPLEMENT

Safe tractor transport requires the operator possess a thorough knowledge of the model being operated and precautions to take while driving with an attached implement. Ensure the tractor has the capacity to handle the weight of the implement and the tractor operating controls are set for safe transport. To ensure safety while driving the tractor with an attached implement, review the following. *OPS-U- 0012*



Never run the Tractor engine in a closed building or without adequate ventilation. The exhaust fumes can be hazardous to your health. (SG-23)



Transport only at speeds where you can maintain control of the equipment. Serious accidents and injuries can result from operating this equipment at high speeds. Understand the Tractor and Implement and how it handles before transporting on streets and highways. Make sure the Tractor steering and brakes are in good condition and operate properly.



Before transporting the Tractor and Implement, determine the proper transport speeds for you and the equipment. Make sure you abide by the following rules:

Test the tractor at a slow speed and increase the speed slowly. Apply the Brakes smoothly to determine the stopping characteristics of the Tractor and Implement. As you increase the speed of the Tractor the stopping distance increases. Determine the maximum transport speed not to exceed 20 mph (30 kph) for transporting this equipment.

Test the equipment at a slow speed in turns. Increase the speed through the turn only after you determine that the equipment can be operated at a higher speed. Use extreme care and reduce your speed when turning sharply to prevent the tractor and implement from turning over. Determine the maximum turning speed for you and this equipment before operating on roads or uneven ground.

Only transport the Tractor and Implement at the speeds which allow you to properly control the equipment.

Be aware of the operating conditions. Do not operate the Tractor with weak or faulty brakes or worn tires. When operating down a hill or on wet or rain slick roads, the braking distance increases: use extreme care and reduce your speed. When operating in traffic always use the Tractor's flashing warning lights and reduce your speed. Be aware of traffic around you and watch out for the other guy. (SG-19)



OPERATION

8.1 Starting the Tractor

The procedure to start the tractor is model specific. Refer to the tractor operator's manual for starting procedures for your particular tractor. Consult an authorized dealer if the starting procedure is unclear. Ensure the 3-point control lever is in the lowered position and the PTO is disengaged before starting the tractor. OPS-U-0033



8.2 Brake and Differential Lock Setting

Make sure the tractor brakes are in good operating condition. Tractor brakes can be set to operate independently allowing single rear wheel braking action or locked together to provide simultaneous rear wheel braking. FOR MOST DRIVING AND OPERATING CONDITIONS, THE BRAKE PEDALS SHOULD BE LOCKED TOGETHER TO PROVIDE THE MOST EFFECTIVE BRAKING ACTION.

Always disengage the tractor differential lock when turning. When engaged the differential lock will prevent or limit the tractor from turning. During normal cutting conditions, locking the differential provides no benefit and should not be used. OPS-U-0013

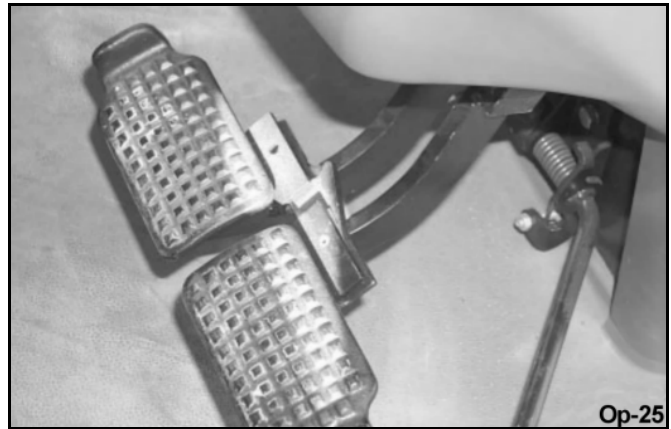

WARNING

Be aware of the operating conditions. Do not operate the Tractor with weak or faulty brakes. When operating down a hill or on wet or rain slick roads, the braking distance increases; use extreme care and reduce your speed in these conditions. When operating in traffic, always use the Tractor's flashing warning lights and reduce your speed. Be aware of traffic around you and watch out for the other guy.

OPERATION

8.3 Driving the Tractor and Implement

Start off driving at a slow speed and gradually increase your speed while maintaining complete control of the tractor and implement. Moving slowly at first will also prevent the tractor from rearing up and loss of steering control. The tractor should never be operated at speeds that cannot be safely handled or which will prevent the operator from stopping quickly during an emergency. If the power steering or engine ceases operating, stop the tractor immediately as the tractor will be difficult to control.

Perform turns with the tractor and implement at slow speeds to determine how the tractor with an attached implement handles a turn. Determine the safe speed to maintain proper control of the tractor when making turns. When turning with a towed implement, the overall working length of the unit is increased. Allow additional clearance for the implement when turning.

To avoid overturns, drive the tractor with care and at safe speeds, especially when operating over rough ground, crossing ditches or slopes, and turning corners. Tractor wheel tread spacing should be increased when working on inclines or rough ground to reduce the possibility of tipping.

Use extreme caution when operating on steep slopes. Keep the tractor in a low gear when going downhill. DO NOT coast or free-wheel downhill.
OPS-RK-0006



9. OPERATING THE TRACTOR AND IMPLEMENT

THE OPERATOR MUST COMPLETELY UNDERSTAND HOW TO OPERATE THE TRACTOR AND IMPLEMENT AND ALL CONTROLS BEFORE ATTEMPTING TO OPERATE. The operator must read and understand the Safety and Operation Sections of the implement and tractor operator's manuals. These manuals must be read and explained to any operator who cannot read. Never allow someone to operate the implement and tractor without complete operating instructions.

Before starting any operation, the operator must become familiar with the area to be worked in and any obstacles and hazards contained within to ensure safety to the operator, bystanders, and equipment. Special attention should be paid to foreign debris, rough terrain, steep slopes, and passersby and animals in the area.
OPS-U- 0015

OPERATION

9.1 Foreign Debris Hazards

Before raking, inspect the area to make sure there are no foreign objects that the rake teeth could hit or become entangled with. Remove all foreign objects and debris. If objects are too big to remove, mark them clearly and be sure to prevent the mower blades from contacting them.

If you hit a solid object or foreign debris, stop the implement and tractor at once. Immediately idle the engine speed and disengage the PTO. Wait for all rotating motion to stop, then raise the implement and move the tractor and implement off the object. Inspect the area and remove, or mark the location of the debris. Inspect the condition of the implement and make any needed repairs immediately. Make sure the teeth are not damaged and the tines are uniform before resuming operation.

Always wear your seat belt securely fastened and only operate the tractor and mower with the ROPS in the raised position. If the tractor or implement hits a tree stump, rock, or bump, a sudden movement could throw you off of the seat and under the tractor and/or implement. The seat belt is your best protection from falling off the tractor and the ROPS provides protection from being crushed during a tractor roll-over. *OPS-RK-0007*

9.2 Bystanders/Passersby Precautions

If a bystander comes within 300 feet of the tractor while the mower is being operated, stop the tractor at once, idle the engine and disengage the PTO. Do not engage the PTO again until all bystanders are well past the 300 foot distance. *OPS-R-0024*

9.3 Engaging the Power Take Off (PTO)

Before engaging the PTO, make certain that the area is clear of bystanders and passersby. The implement must be completely lowered and the deck positioned at a safe operating height. NEVER engage the PTO with the implement in the raised position.

Set the tractor engine speed at approximately 1,000 RPM before engaging the PTO. Shift the PTO control to the on position, and slowly increase the engine speed until the PTO is operating at the rated speed. If you hear unusual noises or see or feel abnormal vibrations, disengage the PTO immediately. Inspect the implement to determine the cause of the noise or vibration and repair the abnormality. *OPS-U- 0027*

9.4 PTO RPM and Ground Speed

Ground speed for raking will depend upon the height, type, and density of vegetation to be raked. Recommended speed for efficient rake performance is between 2 and 5 mph(3-8 kph). Operate the rake at its full rated speed to maintain tine speed for a clean raking. Refer to the tractor operator's manual or the tractor instrument panel for the engine speed and gear to provide the required PTO and desired ground speed. Make sure that the rake is operating at its full rated speed before entering the vegetation to be raked. If it becomes necessary to temporarily regulate engine speed, increase or decrease the throttle gradually.

Ground speed is achieved by transmission gear selection and not by the engine operating speed. The operator may be required to experiment with several gear range combinations to determine the best gear and range which provides the most ideal performance from the implement and most efficient tractor operation. As the severity of raking conditions increase, the ground speed should be decreased by selecting a lower gear to maintain the proper operating PTO speed. *OPS-RK-0008*

OPERATION

OPERATION

Stay alert and watch for trees, low hanging limbs, power lines, and other overhead obstacles and solid ground objects while you are operating. Use care to avoid hitting these items. OPS-R-0028_A



9.5 Shutting Down the Implement

To shut down attached mower head, first bring the tractor to a complete stop. Decrease engine RPM to idle then disengage cutterhead. The mower head will come to a complete stop within a suitable amount of time. Do not engage or disengage the cutterheads at a high RPM unless there is an emergency situation.



Park the tractor on a level surface, place the transmission in park or neutral and apply the parking brake, lower the attached implement to the ground, shut down the engine, remove the key, and wait for all motion to come to a complete stop before exiting the tractor. OPS-U- 0016



OPERATION

10. DISCONNECTING THE IMPLEMENT FROM THE TRACTOR

Before disconnecting the implement, the PTO must be disengaged and tire wheel rotation at a complete stop. Move the implement to a level storage location and lower it to the ground. If the implement is not resting securely on the ground, block the implement up securely before attempting to disconnect it from the tractor.

Use extreme care to keep feet and hands from under the implement and clear of any pinch points caused by the tractor hitch arms and implement pins. OPS-RK-0009



Always shut the Tractor completely down, place the transmission in park, and set the parking brake before you or anyone else attempts to connect or disconnect the Implement and Tractor hitches. (S3PT-15)



Never unhitch without using the Tongue Jack. The Tongue is very heavy. Attempting to lift the Tongue without using the Tongue Jack could cause strains or other injury. Allowing the tongue to fall suddenly and unexpectedly could result in crushing injury. Use the Tongue Jack for lifting the Implement only. Overloading the Tongue Jack can cause failure with possible serious bodily injury or even death. (STI-04)

OPERATION

11. RAKE STORAGE

Properly preparing and storing the implement at the end of the season is critical to maintaining its appearance and to help ensure years of dependable service. The following are suggested storage procedures:

- Thoroughly clean all debris off the implement to prevent damage from rotting hay and standing water.
- Lubricate all implement grease points and fill gearbox oil levels as detailed in the maintenance section.
- Tighten all bolts and pins to the recommended torque.
- Check the implement for worn and damaged parts. Perform repairs and make replacements immediately so that the implement will be ready for use at the start of the next season.
- Store the implement in a clean, dry place with the implement housing resting securely on blocks or at ground level.
- Keep the implement from sitting in water, dirt and other contaminants.
- Use spray touch-up enamel where necessary to prevent rust and maintain the appearance of the rake. *OPS-RK-0010*



Never allow children or other persons to ride on the Tractor or Implement. Falling off can result in serious injury or death. (SG-10)



12. TRANSPORTING THE TRACTOR AND IMPLEMENT

Inherent hazards of operating the tractor and implement and the possibility of accidents are not left behind when you finish working in an area. Therefore, the operator must employ good judgement and safe operation practices when transporting the tractor and implement between locations. By using good judgement and following safe transport procedures, the possibility of accidents while moving between locations can be substantially minimized. *OPS-U-0017*

OPERATION

Before transporting the tractor and implement, idle the tractor engine, disengage the PTO and wait for all moving parts to come to a complete stop. Once all implement parts are completely stopped, raise the implement to transport height. *OPS-RK-0011*



Before transporting the tractor on a public roadway or boarding a trailer for transport, the tractor brake pedals should be locked together. Locking the pedals ensures that both wheels brake simultaneously while stopping, especially when making an emergency stop.

Use extreme caution and avoid hard applications of the tractor brakes when towing heavy loads at road speeds. Never tow the implement at speeds greater than 20 MPH (32 kph). *OPS-U-0018*

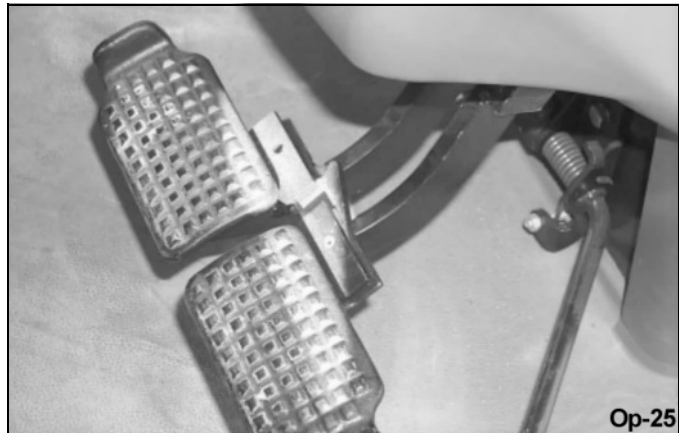

OPERATION

12.1 Transporting

To transport the machine, it is necessary to raise the hay rakes which can be done from the tractor using the hydraulic lever. It is not necessary to move the hay rakes from the working position in order to raise them.

When moving a short distance in the field, it is not necessary to lock the hay rakes; however, when leaving the field, the safety locks must be used.

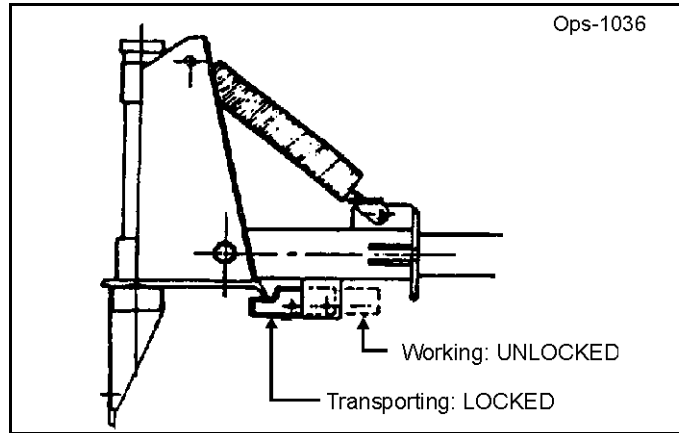

WARNING

While transporting the machine, the safety locks must always be locked, and while working, the safety locks must always be unlocked.

For safety reasons, after raising the side arms, attach the chain (55) to the two supports (8) and (10) by connecting the hooks (56) to pins (T).

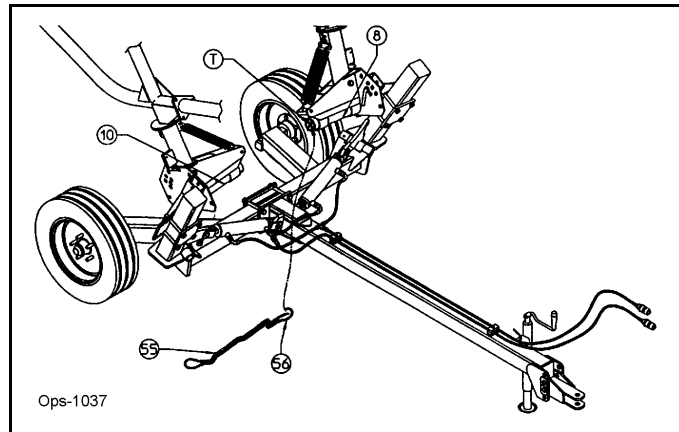

WARNING

The chain must be removed before putting the arms back into the working position.

OPERATION

12.2 Transporting on Public Roadways

Extreme caution should be used when transporting the tractor and implement on public roadways. The tractor must be equipped with all required safety warning features including a SMV emblem and flashing warning lights to alert drivers of the tractor's presence. Remember that roadways are primarily designed for automotive drivers and most drivers will not be looking out for you, therefore, you must look out for them. Check your side view mirrors frequently and remember that vehicles will approach quickly because of the tractor's slower speed. Be extremely cautious when the piece of equipment that you are towing is wider than the tractor tire width and/or extends beyond your lane of the road.

Make sure that a proper size safety tow chain is secured between the tractor and implement before entering a public road. OPS-U- 0019



Make certain that the "Slow Moving Vehicle" (SMV) sign is installed in such a way as to be clearly visible and legible. When transporting the Equipment use the Tractor flashing warning lights and follow all local traffic regulations. (SG-6)

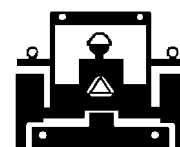

The SMV (Slow-Moving Vehicle) emblem is universal symbol used to alert drivers of the presence of equipment traveling on roadways at a slow speed. SMV signs are a triangular bright orange with reflective red trim for both easy day and night visibility. Make sure the SMV sign is clean and visible from the rear of the unit before transporting the tractor and implement on a public roadway. Replace the SMV emblem if faded, damaged, or no longer reflective. OPS-U- 0020



Op-43

Make sure that all tractor flashing warning lights, headlights, and brake/tail lights are functioning properly before proceeding onto public roads. While newer model tractors have plenty of lighting to provide warning signals and operating lighting, most older models are only equipped with operating lights. Consult an authorized tractor dealer for lighting kits and modifications available to upgrade the lighting on older tractor models. OPS-U- 0021



Op-595

OPERATION

OPERATION

When operating on public roads, have consideration for other road users. Pull to the side of the road occasionally to allow all following traffic to pass. Do not exceed the legal speed limit set in your country for agricultural tractors. Always stay alert when transporting the tractor and implement on public roads. Use caution and reduce speed if other vehicles or pedestrians are in the area. *OPS-U- 0022*



Reduce speed before turning or applying the brakes. Ensure that both brake pedals are locked together when operating on public roads. *OPS-U- 0023*

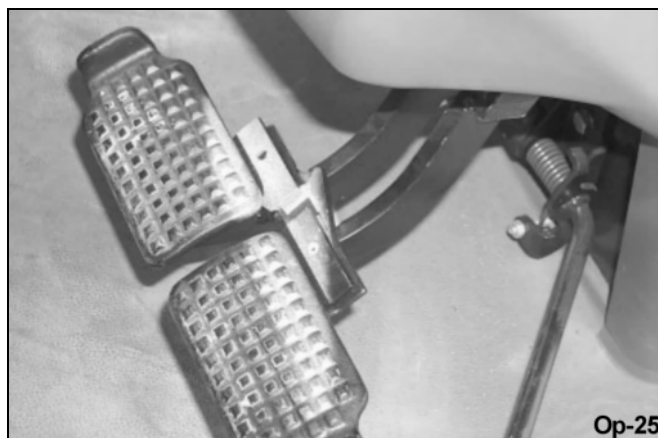

12.3 Hauling the Tractor and Implement

Before transporting a loaded tractor and implement, measure the height and width dimensions and gross weight of the complete loaded unit. Ensure that the load will be in compliance with the legal limits set for the areas that will be traveled through. *OPS-U- 0024*



OPERATION

Use adequately sized and rated trailers and equipment to transport the tractor and implement. Consult an authorized dealer to determine the proper equipment required. Using adequately sized chains, heavy duty straps, cables and/or binders, securely tie down both the front and rear of the tractor utilizing the proper tie down locations as specified by the tractor manufacturer. *OPS-U- 0025*



Arrange the chains so that when tightened, the chains are pulling downward and against themselves. Carefully tighten the securing chains or other fasteners using boomers or binders to apply maximum tension. Use extreme care when attaching and removing the securing devices as the extreme tension involved when released has the potential to inflict serious injury.

While hauling the tractor and implement, make occasional stops to check that the tractor and implement have not moved or shifted and that the securing chains have maintained tension. If during transport a hard braking, sharp turning, or swerving action was performed, stop at the next safe location to inspect the security of the load. *OPS-U- 0026*



OPERATION

OPERATION

13. TROUBLESHOOTING GUIDE

| Problem | Possible Cause | Remedy |
|----------------------------------|--|---|
| Hay carrying over on the wheels. | Teeth not polished. Mud collected on tine ends. | Operate rake on gravel surface for a short distance. Dew on hay, wait until dry. Do not run in soft, wet ground. |
| Tooth Breakage. | Backing with teeth in contact with ground. Too much of rake weight on wheels. Corrosion in storage. | Avoid backing with teeth on ground. Raise the 3-point hitch slightly. Coat teeth with grease or oil during storage. |
| Rake missing hay. | Wheels running too fast. Wheels not pitched back enough. Teeth missing or worn. | Adjust angle at sector plate. Pitch wheels back by adjusting 3-point top link. Replace teeth. It is best to replace all teeth at the same time to maintain uniform tine height. |
| Rake wheels bounce excessively. | Wheels have too little ground weight. | Lower 3-point hitch. |
| Bent teeth. | Backing with wheels down. Excessive speed on rough terrain. Narrow or deep ditches or furrows, rocky ground. Too much weight on wheels. | Avoid backing with teeth down. Reduce speed. Avoid or cross slowly. Raise 3-point slightly. |

OPERATION

13. TROUBLESHOOTING GUIDE

| Problem | Possible Cause | Remedy |
|----------------------------------|--|--|
| Hay carrying over on the wheels. | Teeth not polished. | Operate rake on gravel surface for a short distance. Dew on hay, wait until dry. Do not run in soft, wet ground. |
| | Mud collected on tine ends. | |
| Tooth Breakage. | Backing with teeth in contact with ground. | Avoid backing with teeth on ground. |
| | Too much of rake weight on wheels. | Raise the 3-point hitch slightly. |
| | Corrosion in storage. | Coat teeth with grease or oil during storage. |
| Rake missing hay. | Wheels running too fast. | Adjust angle at sector plate. |
| | Wheels not pitched back enough. | Pitch wheels back by adjusting 3-point top link. |
| | Teeth missing or worn. | Replace teeth. It is best to replace all teeth at the same time to maintain uniform tine height. |
| Rake wheels bounce excessively. | Wheels have too little ground weight. | Lower 3-point hitch. |
| Bent teeth. | Backing with wheels down. | Avoid backing with teeth down. |
| | Excessive speed on rough terrain. | Reduce speed. |
| | Narrow or deep ditches or furrows, rocky ground. | Avoid or cross slowly. |
| | Too much weight on wheels. | Raise 3-point slightly. |

MAINTENANCE SECTION

Maintenance Section 5-1

MAINTENANCE

MAINTENANCE



ANY REPAIR WORK MUST BE CARRIED OUT WITH THE MACHINE AT REST AND DISCONNECTED FROM THE TRACTOR.



DO NOT CARRY OUT WELDING WITHOUT AUTHORIZATION AND INSTRUCTION FROM THE MANUFACTURER.



DISCONNECT THE MACHINE FROM THE TRACTOR BEFORE ANY WELDING WORK. DAMAGE TO BATTERY COULD RESULT.



ALWAYS USE A PROTECTIVE MASK, GOGGLES AND GLOVES WHEN WELDING, SANDING OR GRINDING OR WHEN USING A HAMMER OR DRILL.



ALWAYS WORK ON THE MACHINE OUT OF DOORS. IF YOU HAVE TO OPERATE THE MACHINE WHEN CONNECTED TO THE TRACTOR IN AN ENCLOSED AREA (WHEN TESTING AFTER REPAIR OR MAINTENANCE), ENSURE THAT THERE IS SUFFICIENT VENTILATION SO AS TO PREVENT NOXIOUS EXHAUST GASES FROM ACCUMULATING.



DO NOT USE GASOLINE, SOLVENTS OR OTHER FLAMMABLE LIQUIDS AS DETERGENTS.



USE COMMERCIAL NON-FLAMMABLE AND NON-TOXIC SOLVENTS.



DO NOT USE COMPRESSED AIR OR WATER AT HIGH PRESSURE TO CLEAN THE MACHINE. IF THIS IS UNAVOIDABLE, THEN WEAR GOGGLES WITH SIDE PROTECTION AND LIMIT THE PRESSURE AS MUCH AS POSSIBLE. WHEN THE WORK IS FINISHED, AND WITH THE MACHINE DISCONNECTED FROM THE TRACTOR, INSPECT AND CHECK THE MACHINE COMPLETELY.

The following should be noted if the machine is scrapped:

The machine consists mainly of ferrous material which must be disposed of according to the regulations in force in the country concerned.

There is also a small amount of plastic which must be disposed of according to the regulations in force in the country concerned.

MAINTENANCE

STORAGE

To prepare your Rake for storage:

1. Clean the rake following instructions and allow it to dry.
2. Thoroughly tighten all screws and bolts.
3. Store the rake on a clean, dry surface in the down (working) position.
4. Grease the machine thoroughly and then cover it completely and store in a dry place.
5. Lubricate all points and slides before storage. This prevents corrosion.

NOTE: Now would be a good time to replace all damaged or worn parts, and have a machine in perfect condition ready for use the next season.

Important

During extended periods of inactivity it is necessary to close the cylinders completely. This must be done in is such a way as to protect the rods from weather effects.

The rods remaining outside the cylinder (whatever reason may be) must be carefully protected with a grease layer.

MAINTENANCE

MAINTENANCE

LUBRICATION

Before testing for operation, it is necessary to lubricate and check the movement of all parts. The following diagram gives the maintenance program to be carried out in its entirety the first time and subsequently according to the schedule as shown. Keep all lubrication fittings free of dirt and contaminants.

| | | | |
|----------|---|------------|------------------------------------|
| A | Double Wing Hinge | (1) | Every 8 Hours of Operation |
| B | Wing Caster Wheel | (1) | Every 8 Hours of Operation |
| C | Cylinder Slide Mount | (2) | Every 8 Hours of Operation |
| D | Wing to Axle Support (Top Surface of Axle) | (2) | Every 8 Hours of Operation |
| E | Rake Mounting Brackets | (1) | Every 20 Hours of Operation |
| F | Swivel Hitch | (2) | Every 20 Hours of Operation |
| G | Jack Crank | (2) | Every 6 Months of Operation |
| H | Wheel Bearing | (3) | Every 6 Months of Operation |

(1) Grease zerk until excess escapes
 (2) Smear grease on contact surfaces
 (3) Clean and repack with grease

Mnt-RK-0004

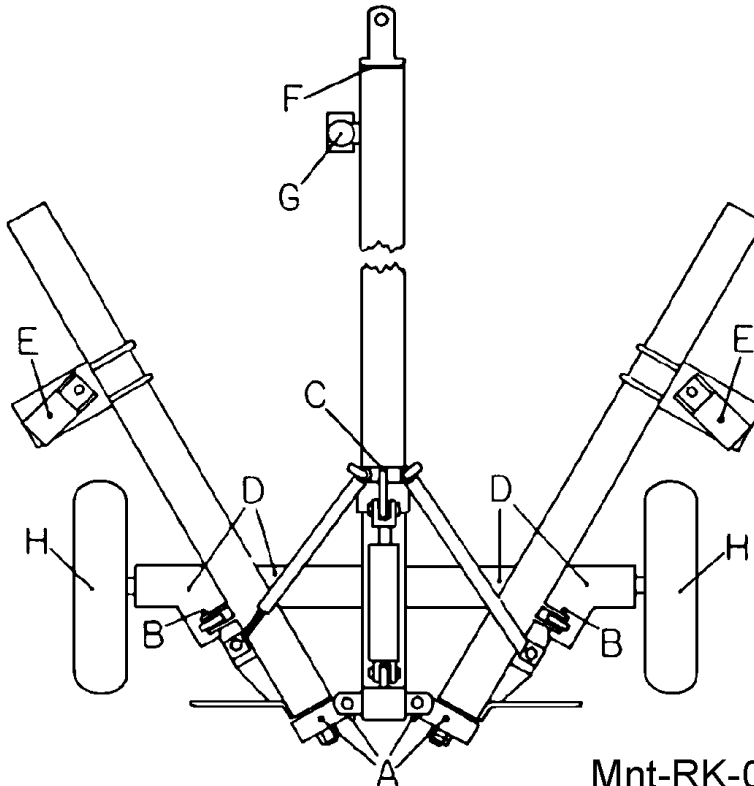

MAINTENANCE

MAINTENANCE

BOLT TORQUE VALUES

Because of the severe operating conditions, correct bolt torque is very important. An improperly torqued bolt can be easily shaken loose or broken by the vibrations. When replacing bolts, always use the same grade of bolt as used originally. Use this chart as a guide to tightening all bolts. Torque values listed are for general use only.

TORQUE SPECIFICATIONS

Proper torque for American fasteners.
Recommended Torque in Foot Pounds (Newton Meters).*

AMERICAN Bolt Head Markings

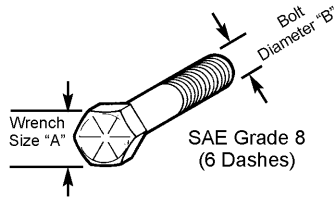

| WRENCH SIZE (IN.) "A" | BOLT DIAMETER (IN.) "B" AND THREAD SIZE | SAE GRADE 2 | SAE GRADE 5 | SAE GRADE 8 |
|-----------------------|---|-------------|-------------|-------------|
| 7/16 | 1/4 - 20 UNC | 6 (7) | 8 (11) | 12 (16) |
| 7/16 | 1/4 - 28 UNF | 6 (8) | 10 (13) | 14 (18) |
| 1/2 | 5/16 - 18 UNC | 11 (15) | 17 (23) | 25 (33) |
| 1/2 | 5/16 - 24 UNF | 13 (17) | 19 (26) | 27 (37) |
| 9/16 | 3/8 - 16 UNC | 20 (27) | 31 (42) | 44 (60) |
| 9/16 | 3/8 - 24 UNF | 23 (31) | 35 (47) | 49 (66) |
| 5/8 | 7/16 - 14 UNC | 32 (43) | 49 (66) | 70 (95) |
| 5/8 | 7/16 - 20 UNF | 36 (49) | 55 (75) | 78 (106) |
| 3/4 | 1/2 - 13 UNC | 49 (66) | 76 (103) | 106 (144) |
| 3/4 | 1/2 - 20 UNF | 55 (75) | 85 (115) | 120 (163) |
| 7/8 | 9/16 - 12 UNC | 70 (95) | 109 (148) | 153 (207) |
| 7/8 | 9/16 - 18 UNF | 79 (107) | 122 (165) | 172 (233) |
| 15/16 | 5/8 - 11 UNC | 97 (131) | 150 (203) | 212 (287) |
| 15/16 | 5/8 - 18 UNF | 110 (149) | 170 (230) | 240 (325) |
| 1-1/8 | 3/4 - 10 UNC | 144 (195) | 266 (360) | 376 (509) |
| 1-1/8 | 3/4 - 16 UNF | 192 (260) | 297 (402) | 420 (569) |
| 1-5/16 | 7/8 - 9 UNC | 166 (225) | 430 (583) | 606 (821) |
| 1-5/16 | 7/8 - 14 UNF | 184 (249) | 474 (642) | 668 (905) |
| 1-1/2 | 1 - 8 UNC | 250 (339) | 644 (873) | 909 (1232) |
| 1-1/2 | 1 - 12 UNF | 274 (371) | 705 (955) | 995 (1348) |
| 1-1/2 | 1 - 14 UNF | 280 (379) | 721 (977) | 1019 (1381) |
| 1-11/16 | 1-1/8 - 7 UNC | 354 (480) | 795 (1077) | 1288(1745) |
| 1-11/16 | 1-1/8 - 12 UNF | 397 (538) | 890 (1206) | 1444 (1957) |
| 1-7/8 | 1-1/4 - 7 UNC | 500 (678) | 1120 (1518) | 1817 (2462) |
| 1-7/8 | 1-1/4 - 12 UNF | 553 (749) | 1241 (1682) | 2013 (2728) |
| 2-1/16 | 1-3/8 - 6 UNC | 655 (887) | 1470 (1992) | 2382 (3228) |
| 2-1/16 | 1-3/8 - 12 UNF | 746 (1011) | 1672 (2266) | 2712 (3675) |
| 2-1/4 | 1-1/2 - 6 UNC | 870 (1179) | 1950 (2642) | 3161 (4283) |
| 2-1/4 | 1-1/2 - 12 UNF | 979 (1327) | 2194 (2973) | 3557 (4820) |

METRIC

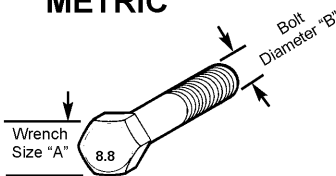

Numbers appearing on bolt heads indicate ASTM class.

*Use 75% of the specified torque value for plated fasteners. Use 85% of the specified torque values for lubricated fasteners.

Proper torque for Metric fasteners.
Recommended torque in Foot Pounds (Newton Meters).*

| WRENCH SIZE (mm) "A" | BOLT DIA. (mm) "B" | ASTM 4.6 | ASTM 8.8 | ASTM 9.8 | ASTM 10.9 |
|----------------------|--------------------|-----------|-------------|-----------|-------------|
| 8 | 5 | 1.8 (2.4) | | 5.1 (6.9) | 6.5 (8.8) |
| 10 | 6 | 3 (4) | | 8.7 (12) | 11.1 (15) |
| 13 | 8 | 7.3 (10) | | 21.1 (29) | 27 (37) |
| 16 | 10 | 14.5 (20) | | 42 (57) | 53 (72) |
| 18 | 12 | 25 (34) | 74 (100) | 73 (99) | 93 (126) |
| 21 | 14 | 40 (54) | 118 (160) | 116 (157) | 148 (201) |
| 24 | 16 | 62 (84) | 167 (226) | 181 (245) | 230 (312) |
| 30 | 20 | 122 (165) | 325 (440) | | 449 (608) |
| 33 | 22 | | 443 (600) | | 611 (828) |
| 36 | 24 | 211 (286) | 563 (763) | | 778 (1054) |
| 41 | 27 | | 821 (1112) | | 1138 (1542) |
| 46 | 30 | 418 (566) | 1119 (1516) | | 1547 (2096) |

Mnt-B-0005

RHINO

LIMITED WARRANTY

1. LIMITED WARRANTIES

- 1.01. Rhino warrants for one year from the purchase date to the original non-commercial, governmental, or municipal purchaser ("Purchaser") and warrants for six months to the original commercial or industrial purchaser ("Purchaser") that the goods purchased are free from defects in material or workmanship.
- 1.02. Manufacturer will replace for the Purchaser any part or parts found, upon examination at one of its factories, to be defective under normal use and service due to defects in material or workmanship.
- 1.03. This limited warranty does not apply to any part of the goods which has been subjected to improper or abnormal use, negligence, alteration, modification, or accident, damaged due to lack of maintenance or use of wrong fuel, oil, or lubricants, or which has served its normal life. This limited warranty does not apply to any part of any internal combustion engine, or expendable items such as blades, shields, guards, or pneumatic tires except as specifically found in your Operator's Manual.
- 1.04. Except as provided herein, no employee, agent, Dealer, or other person is authorized to give any warranties of any nature on behalf of Manufacturer.

2. REMEDIES AND PROCEDURES.

- 2.01. This limited warranty is not effective unless the Purchaser returns the Registration and Warranty Form to Manufacturer within 30 days of purchase.
- 2.02. Purchaser claims must be made in writing to the Authorized Dealer ("Dealer") from whom Purchaser purchased the goods or an approved Authorized Dealer ("Dealer") within 30 days after Purchaser learns of the facts on which the claim is based.
- 2.03. Purchaser is responsible for returning the goods in question to the Dealer.
- 2.04. If after examining the goods and/or parts in question, Manufacturer finds them to be defective under normal use and service due to defects in material or workmanship, Manufacturer will:
 - (a) Repair or replace the defective goods or part(s) or
 - (b) Reimburse Purchaser for the cost of the part(s) and reasonable labor charges (as determined by Manufacturer) if Purchaser paid for the repair and/or replacement prior to the final determination of applicability of the warranty by Manufacturer.

The choice of remedy shall belong to Manufacturer.

- 2.05. Purchaser is responsible for any labor charges exceeding a reasonable amount as determined by Manufacturer and for returning the goods to the Dealer, whether or not the claim is approved. Purchaser is responsible for the transportation cost for the goods or part(s) from the Dealer to the designated factory.

3. LIMITATION OF LIABILITY.

- 3.01. MANUFACTURER DISCLAIMS ANY EXPRESS (EXCEPT AS SET FORTH HEREIN) AND IMPLIED WARRANTIES WITH RESPECT TO THE GOODS INCLUDING, BUT NOT LIMITED TO, MERCHANTABILITY AND FITNESS FOR A PARTICULAR PURPOSE.
- 3.02. MANUFACTURER MAKES NO WARRANTY AS TO THE DESIGN, CAPABILITY, CAPACITY, OR SUITABILITY FOR USE OF THE GOODS.
- 3.03. EXCEPT AS PROVIDED HEREIN, MANUFACTURER SHALL HAVE NO LIABILITY OR RESPONSIBILITY TO PURCHASER OR ANY OTHER PERSON OR ENTITY WITH RESPECT TO ANY LIABILITY, LOSS, OR DAMAGE CAUSED OR ALLEGED TO BE CAUSED DIRECTLY OR INDIRECTLY BY THE GOODS INCLUDING, BUT NOT LIMITED TO, ANY INDIRECT, SPECIAL, CONSEQUENTIAL, OR INCIDENTAL DAMAGES RESULTING FROM THE USE OR OPERATION OF THE GOODS OR ANY BREACH OF THIS WARRANTY. NOT WITHSTANDING THE ABOVE LIMITATIONS AND WARRANTIES, MANUFACTURER'S LIABILITY HEREUNDER FOR DAMAGES INCURRED BY PURCHASER OR OTHERS SHALL NOT EXCEED THE PRICE OF THE GOODS.
- 3.04. NO ACTION ARISING OUT OF ANY CLAIMED BREACH OF THIS WARRANTY OR TRANSACTIONS UNDER THIS WARRANTY MAY BE BROUGHT MORE THAN TWO (2) YEARS AFTER THE CAUSE OF ACTION HAS OCCURRED.

4. MISCELLANEOUS.

- 4.01. Proper Venue for any lawsuits arising from or related to this limited warranty shall be only in Guadalupe County, Texas.
- 4.02. Manufacturer may waive compliance with any of the terms of this limited warranty, but no waiver of any terms shall be deemed to be a waiver of any other term.
- 4.03. If any provision of this limited warranty shall violate any applicable law and is held to be unenforceable, then the invalidity of such provision shall not invalidate any other provisions herein.
- 4.04. Applicable law may provide rights and benefits to purchaser in addition to those provided herein.

KEEP FOR YOUR RECORDS

ATTENTION: Purchaser should fill in the blanks below for his reference when buying repair parts and/or for proper machine identification when applying for warranty.

Rhino Implement Model _____ Serial Number _____

Date Purchased _____ Dealer _____

ATTENTION:

READ YOUR OPERATOR'S MANUAL

RHINO®

1020 S Sangamon Ave.

Gibson City, IL 60936

800-446-5158

Email: parts@servis-rhino.com





TO THE OWNER/OPERATOR/DEALER

To keep your implement running efficiently and safely, read your manual thoroughly and follow these directions and the Safety Messages in this Manual. The Table of Contents clearly identifies each section where you can easily find the information you need.

The OCCUPATIONAL SAFETY AND HEALTH ACT (1928.51 Subpart C) makes these minimum safety requirements of tractor operators:

REQUIRED OF THE OWNER:

1. Provide a Roll-Over-Protective Structure that meets the requirements of this Standard; and
2. Provide Seat belts that meet the requirements of this paragraph of this Standard and SAE J4C; and
3. Ensure that each employee uses such Seat belt while the tractor is moving; and
4. Ensure that each employee tightens the Seat belt sufficiently to confine the employee to the protected area provided by the ROPS

REQUIRED OF THE OPERATOR:

1. Securely fasten seat belt if the tractor has a ROPS.
2. Where possible, avoid operating the tractor near ditches, embankments, and holes.
3. Reduce speed when turning, crossing slopes, and on rough, slick, or muddy surfaces.
4. Stay off slopes too steep for safe operation.
5. Watch where you are going - especially at row ends, on roads, and around trees.
6. Do not permit others to ride.
7. Operate the tractor smoothly - no jerky turns, starts, or stops.
8. Hitch only to the drawbar and hitch points recommended by the tractor manufacturer.
9. When the tractor is stopped, set brakes securely and use park lock, if available.

-
- x Keep children away from danger all day, every day...
 - x Equip tractors with rollover protection (ROPS) and keep all machinery guards in place...
 - x Please work, drive, play and live each day with care and concern for your safety and that of your family and fellow citizens.



RC456
WHEEL RAKE CARRIER

RC456-SOM-02/11
Printed U.S.A

P/N 4702C